OKIDATA[®]
Service Manual

**ML390 Turbo // ML391 Turbo
Dot Matrix Printers**

Adobe Acrobat printable reference
copy of the OKIDATA Service Training Manual.
09/17/97

Note: This Adobe Acrobat version of the Okidata Service Training Manual was built with the pictures rendered at 300 dpi, which is ideal for printing, but does not view on most displays well.

Service Guide ML390/ML391Turbo**0 About This Manual**

Front Cover	1
Copyright / About Information	2

1 Configuration

1.1. Standard Printer Configuration	3
1.2 Options	4

2 Theory of Operation

....2.1.01 Summary	5
....2.1.02 Microprocessor and the Peripheral Circuit	6
.....Printer Block Diagram (Figure 2-1)	7
.....Program ROM	8
.....RAM (MSM51C464A-80RS)	9
.....EEPROM	10
.....Large Scale Integrated Chip (LSI)	11
....2.1.03 Initialization	12
....2.1.04 Parallel Interface Control	13
....2.1.05 Print Control	14
.....Print Compensation Control	15
....2.1.06 Space Motor / Line Feed Motor Control	16
....2.1.07 Operation Panel	17
....2.1.08 Alarm Circuit	18
....2.1.09 Power Supply Circuit	19
2.2.01 Printhead Mechanism and Operation	20
....2.2.02 Spacing Operation	21
....2.2.03 Head Gap Adjusting	22
....2.2.04 Ribbon Drive	23
....2.2.05 Paper Feed Operation	24
.....(1) Cut Sheet and Continuous Forms Switching Mechanism	25
.....(2) Cut-sheet feeder operation	26
.....(3) Continuous Forms Operation (Rear)	27
.....(4) Push and pull tractor mechanism (Option)	28
.....(5) Pull tractor mechanism (option)	29
.....(6) Bottom Push Feed Operation (Option)	30
.....(7) Paper Clamp Mechanism	31
....2.2.06 Paper Detection Mechanism	32
....2.2.07 Automatic Sheet Feed	33
....2.2.08 Paper Park Function (Continuous Forms)	34

3 Assembly/Disassembly

ASSEMBLY/DISASSEMBLY	35
....3.1 Precaution for Parts Replacement	36
....3.2 Service Tools	37

Table of Contents

Page

....3.3 Disassembly/Reassembly Procedure	38
.....How to Change Parts	39
.....3.3.01 Printhead	40
.....3.3.02 Ribbon Protector	41
.....3.3.03 Pull-up Roller Assy	42
.....3.3.04 Upper Cover Assy, Access Cover Assy and Sheet Guide Assy	43
.....3.3.05 Gear Case Assy	44
.....3.3.06 PC Connector	45
.....3.3.07 Space Motor, Guide Roller Assy	46
.....3.3.08 Space Rack	47
.....3.3.09 Carriage Cable	48
.....3.3.10 Backup Roller Holder Assy	49
.....3.3.11 Platen Assy	50
.....3.3.12 Driver Board (SRXD)	51
.....3.3.13 LF Motor	52
.....3.3.14 Operation Panel PCB (LEOP)	53
.....3.3.15 Control/Power Supply Board (SRXC)	54
.....3.3.16 Transformer Assy	55
.....3.3.17 Change Lever and Gears	56
.....3.3.18 Carriage Shaft	57
.....3.3.19 Paper Pan	58
.....3.3.20 Rear Tractor Assy	59
.....3.3.21 Rear Pressure Assy	60
.....3.3.22 Switch Lever	61
4 Adjustments	
4. ADJUSTMENT	62
....4-1-1 Gap between the platen and the printhead	63
....4-1-2 Measure variation of gap when range is changed.	64
4-2 Gap between the platen and the paper pan	65
4-3 Gap between the platen and the pressure roller	66
....4-4-1 Rotation of the push tractor	67
....4-4-2 Backlash between gears	68
....4-5-1 Ribbon feed	69
....4-5-2 Running load to spacing mechanism	70
....4-6 Engagement of the double gear and the LF motor idle gear of the Platen	71
5 Cleaning and Lubrication	
5.1 Cleaning	72
5.2 Lubrication	73
....(1) Cleaning time	74
....(2) Lubricant	75
....(3) Amount of lubricant	76
....(4) Areas to Avoid	77

Table of Contents

Page

.....(5) Lubrication points -- 1. Ribbon feed gear Assy.	78
.....2. Space rack	79
.....3. Platen Assy.	80
.....4. Tractor driving mechanism	81
.....5. Tractor drive shaft	82
.....6. Pressure roller	83
.....7. Pull up roller Assy.	84
.....8. Main chassis Assy.	85
.....9. Carriage Assy.	86
6 Troubleshooting and Repair	
6.1 Items to Check Before Repair	87
6.2 Troubleshooting Table	88
6.3 Lamp Display	89
6.4 Connection Circuit Check for Printhead and SP/LF Motor	90
.....(2) Line Feed Motor	91
.....(3) Space Motor	92
6.5 Troubleshooting Flow Charts	93
.....2 No Spacing Operation (The Alarm LED Blinks)	94
.....3 Homing does not end normally	95
.....4 Paper jam while paper insertion	96
.....5 Smearing/Missing Dots	97
.....6 Faint or dark print	98
.....7 Ribbon feed trouble	99
.....8 Line feed trouble	100
.....9 Malfunction of switch on operation panel	101
.....10 Data receiving failure	102
A PCB Layout	
APPENDIX A: PCB LAYOUT	103
B Parts Listing	
SPARE PARTS LIST	104
....Upper Cover Assembly (Figure 11-1)	105
....Printer General Assembly (Figure 11-2)	106
....Printer Unit (Figure 11-3) [1 of 2]	107
....Printer Unit (Figure 11-3) [2 of 2]	108
....Carriage Option Assembly (Figure 11-4)	109
....Option Spare Parts (Figure 11-5)	110
C RS-232C Serial Interface Board	
APPENDIX C: RS-232C SERIAL INTERFACE BOARD	111
C2. Operation Description	112
.....C2.2.01 Operation at Power On	113
.....C2.2.02 RS-232C Interface	114
....C2.3 Communication Procedure Flowchart	115
.....C2.3.02 Mode B (Figure C-2-3)	116
C3. Troubleshooting Flowcharts	117

Table of Contents**Page**

....C3.3 Local Test

118

.....C3.3.1.2 Function

119



Service Guide ML390/ML391 Turbo

Chapter 0 About This Manual

Disclaimer

This document may not be reproduced without the written permission of Okidata Training and Publications. Every effort has been made to ensure the accuracy of the information contained in this training course. Okidata is not responsible for errors beyond its control.

Copyright / About Information

1996 by Okidata. All rights reserved.

First Release P/N 59274601 November, 1996

Written by:

OKI Data Corporation

11-22, Shibaura 4-chome, Minato-ku, Tokyo 108, Japan

Tel: +81 (Japan)-3 (Tokyo)-5445-6159 Fax: +81-3-5445-6188

Revised by Okidata Training and Publications

Contact

Please address any comments on this publication to:

OKIDATA

Training and Publications

532 Fellowship Road

Mount Laurel, NJ 08054-3499

Okilink Login Name: Technical Training

Internet Web Site: okidata.com

Copyright Listing

OKIDATA is a registered trademark of Oki America, Inc.

OKIDATA est une marque déposée de Oki America, Inc.

Centronics is a registered trademark of Centronics Data Corporation.

Copyright 1997, Okidata, Division of OKI America, Inc. All rights reserved. See the OKIDATA Business Partner Exchange (BPX) for any updates to this material. (<http://bpx.okidata.com>)

1.1. Standard Printer Configuration

This printer consists of the following assemblies:

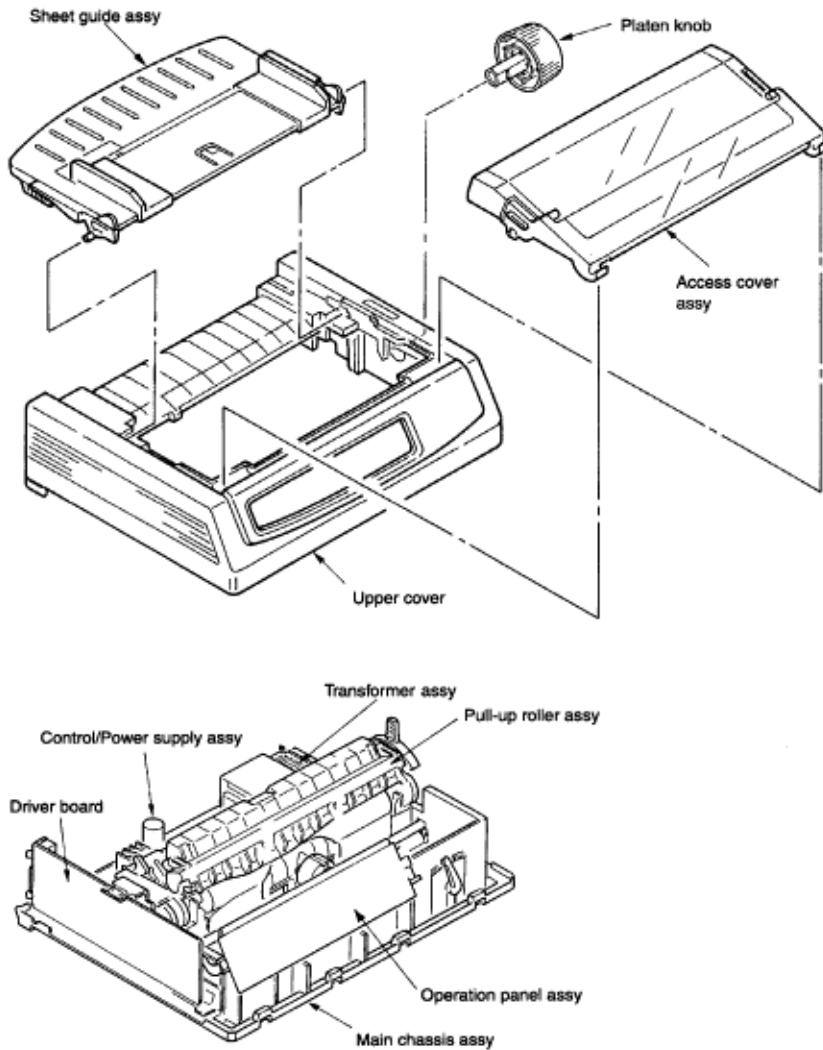

1.2 Options

(1) Cut Sheet Feeder Unit (CSF)

Single-Bin Cut Sheet Feeder

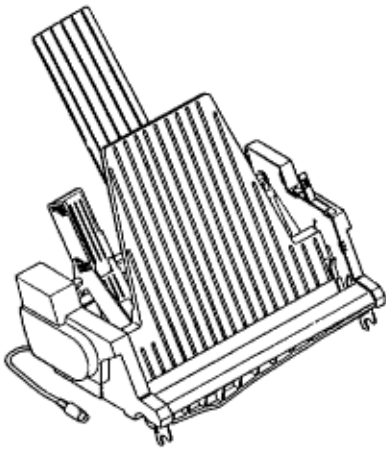

Attachment Assembly

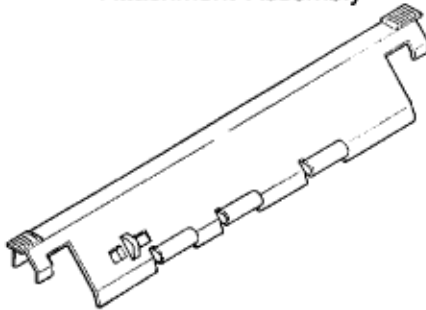

(2) Pull-tractor Assembly

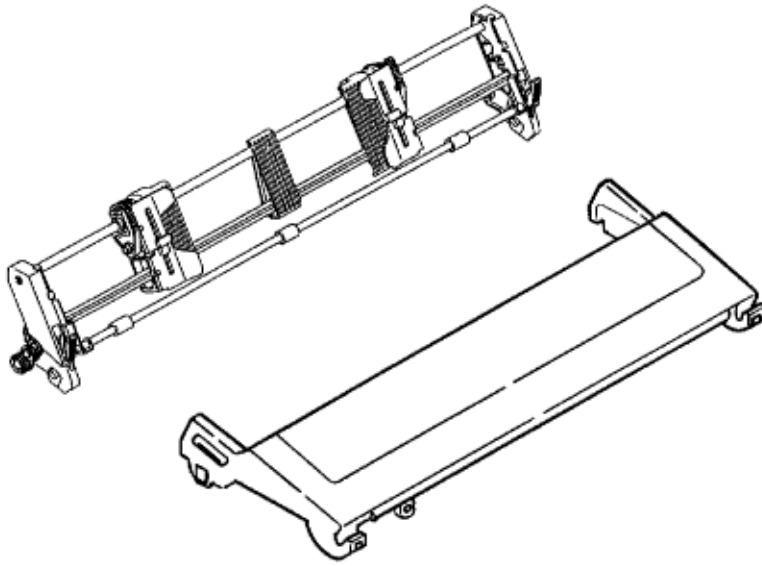

(3) Bottom Push Tractor Unit

Narrow and wide versions available

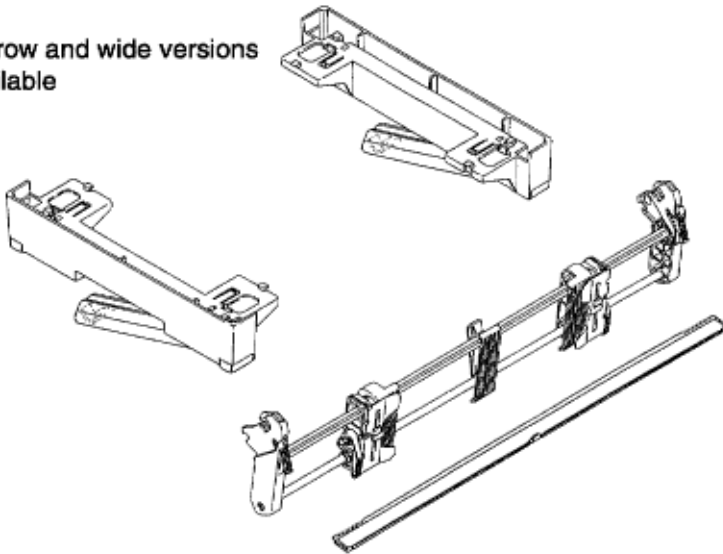

(4) Roll Paper Stand (Narrow only)

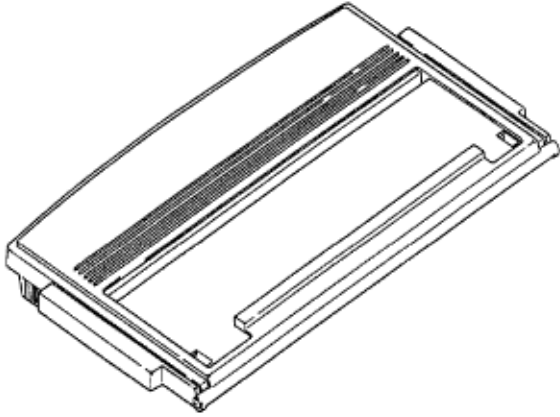

(5) Serial Interface

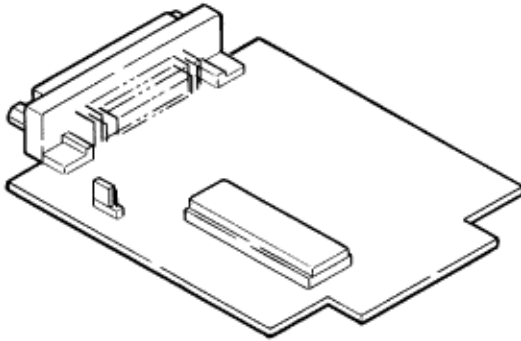

Copyright 1997, Okidata, Division of OKI America, Inc. All rights reserved. See the OKIDATA Business Partner Exchange (BPX) for any updates to this material. (<http://bpx.okidata.com>)

2.1.01 Summary

Figure 2-1 shows the block diagram of the printer.

The control board is made up of the microprocessors, peripheral circuits, drive circuits, sensors and interface connectors.

The power to the control board is supplied by the power board through the connector cord.

The power to other electrical parts is also distributed through the connectors within the control board.

2.1.02 Microprocessor and the Peripheral Circuit

Microprocessor (Q7: 67X640)

This processor is a CMOS single-chip computer with integrated peripheral device functions and a 16 bit MPU core, all OKI original architecture.

The processor has a 20 bit address bus and a 16 bit data bus.

It is capable of accessing up to 1M word program memory and 1M bytes of data memory.

The following characteristics are also provided:

- Built-in type data memory of 512 bytes
- 8-bit 4-channel A/D converter ¥ 1
- 16-bit automatic reload timer ¥ 2
- 8-bit serial port ¥ 2
- 8-bit parallel port ¥ 3 (bitwise I/O specification available)

And others.

The function of this microprocessor is to provide a central mechanism for the entire printer by executing the control program through the LSI and driver circuits.



Service Guide ML390/ML391 Turbo

Chapter 2 Theory of Operation

Printer Block Diagram (Figure 2-1)

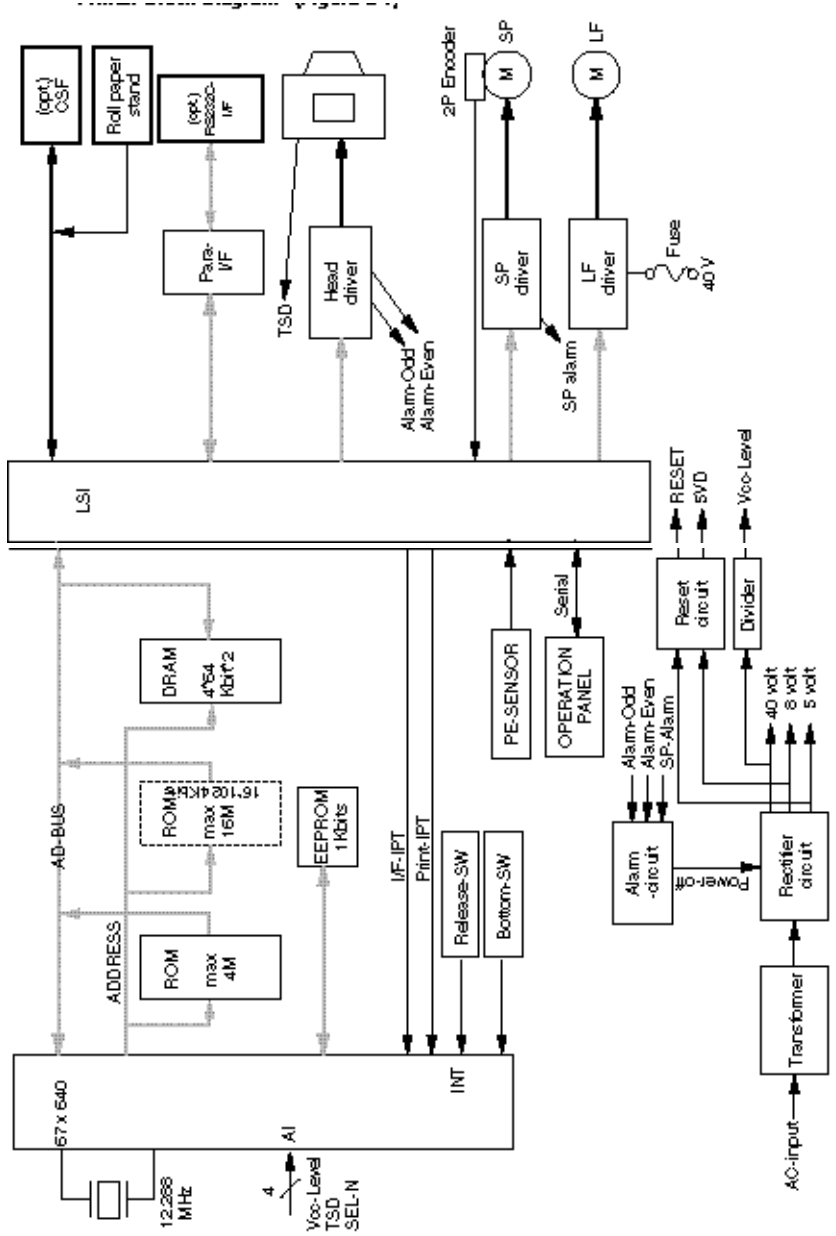



Service Guide ML390/ML391 Turbo

Chapter 2 Theory of Operation

Program ROM

This is a 256 × 16 bits (4M bit) [MAX] EPROM with the control program for the printer stored. The MPU executes instructions under this program.

The program ROM is assigned to the program memory area of the MPU and is fetched by the PSEN signal of the MPU.

The following shows the operation of the memory access.

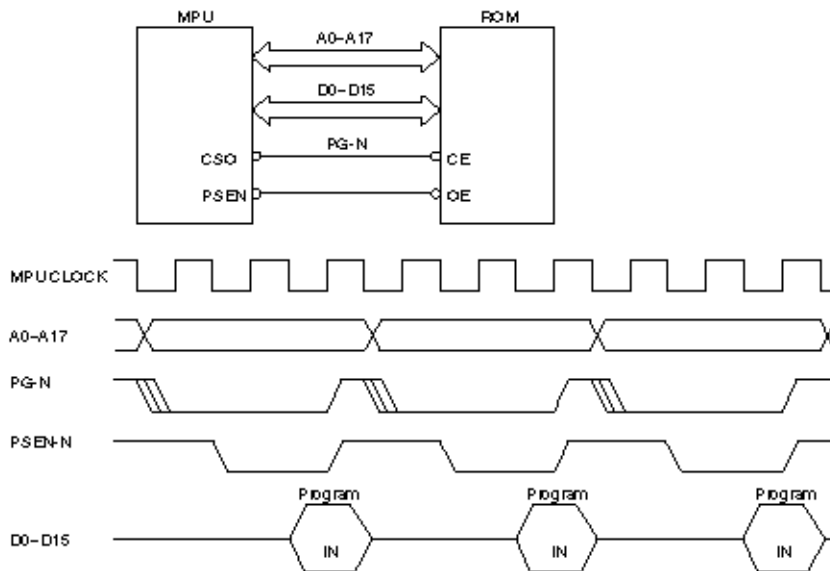

Copyright 1997, Okidata, Division of OKI America, Inc. All rights reserved. See the OKIDATA Business Partner Exchange (BPX) for any updates to this material. (<http://bpx.okidata.com>)



Service Guide ML390/ML391Turbo

Chapter 2 Theory of Operation

RAM (MSM51C464A-80RS)

The RAM is CMOS dynamic RAM with (64K × 4-bit) × 2 configuration, and used as buffers (such as receiving buffer, printing buffer, DLL buffer and working buffer).

The following shows the examples of the memory access operation.

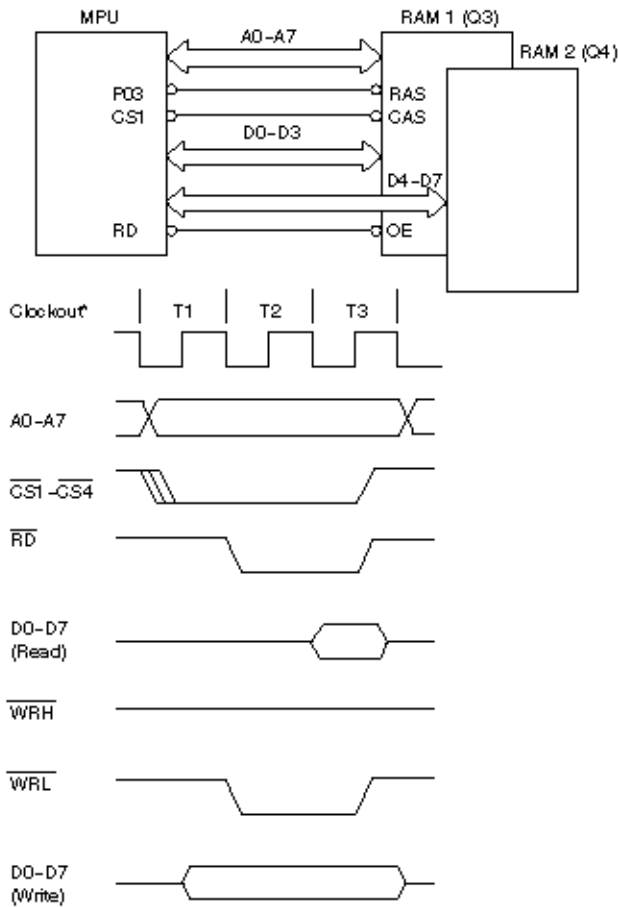



Service Guide ML390/ML391 Turbo

Chapter 2 Theory of Operation

EEPROM

The EEPROM is a CMOS serial I/O type memory which is capable of electrically erasing and writing 1,024 bits.

The EEPROM contains menu data.

The following shows the memory access operation.

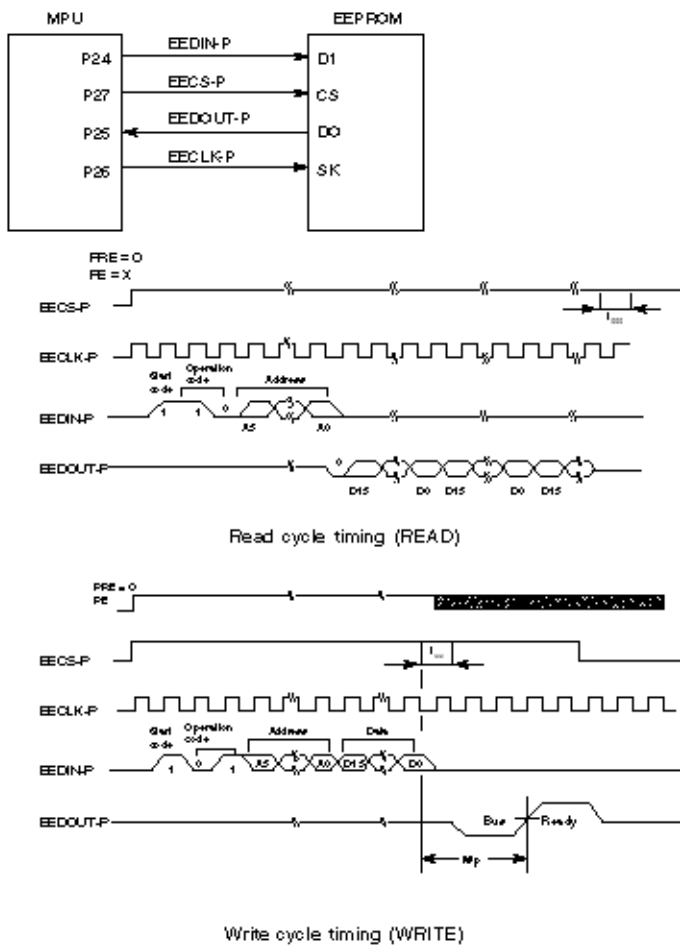



Service Guide ML390/ML391 Turbo

Chapter 2 Theory of Operation

Large Scale Integrated Chip (LSI)

This LSI detects and controls the SP motor speeds by monitoring the two phase sensor signals obtained from the DC motors and modifying the excitation phases as appropriate.

This LSI is connected in multiplex to the MPU.

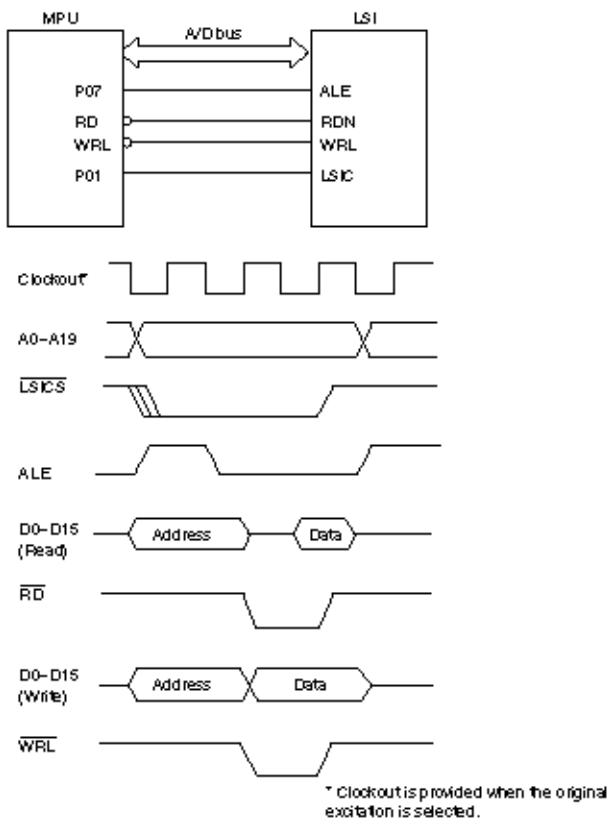



Service Guide ML390/ML391 Turbo

Chapter 2 Theory of Operation

2.1.03 Initialization

This printer is initialized when the power is turned on or when the I-PRIME-N signal is input from the host side via the parallel interface.

For the initialize operation, the RST-N signal is first output from the reset circuit to reset the MPUs and LSIs. When resetting ends, the program starts and the LSIs are reset by MPU via LSIRST-N. Reset operation by I-PRIME starts program to initialize, but does not reset the MPU.

The program here sets the mode of the LSI including the MPU, checks the memories (ROMs and RAMs), then carries out carriage homing, and determines the LF motor phase.

Finally, the program establishes the interface signals (P-I/F: ACK-P signal sending, and S-I/F: BUSY-N signal off) and lights the SELECT lamp to inform the ready state for receiving to the host side and ends the initialize operation.

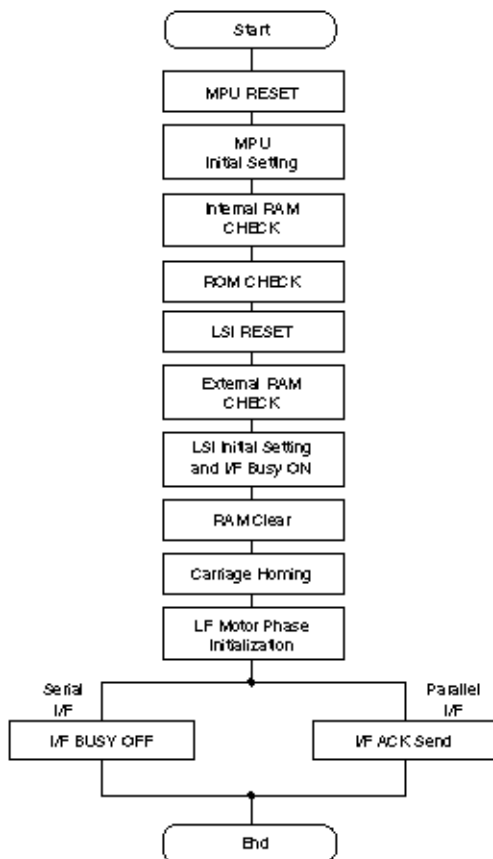

Partner Exchange (BPX) for any updates to this material. (<http://bpx.okidata.com>)

2.1.04 Parallel Interface Control

The parallel data input from the host to the interfaced LSI is latched to its internal register at the falling edge of the STROBE-N signal.

At the same time, the LSI sets the BUSY signal to the high level to inform the host that the data is being processed, and outputs the RXD signal to inform the MPU of data reception. The data is read upon receiving the RD-N signal from the MPU.

When the data processing ends, the BUSY signal is set to off and the ACK-N signal is sent to request the next data. When reception is impossible because the buffer is full, the BUSY signal is sent to request stopping of data transmission.

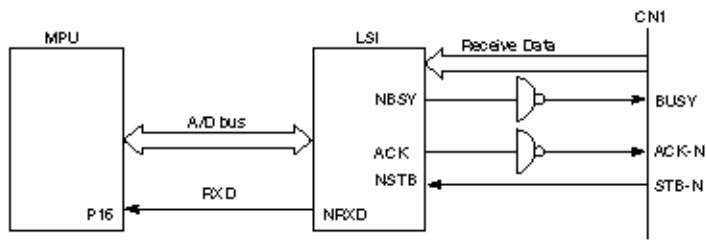

2.1.05 Print Control

Print data is transmitted as parallel data (HEAD1~HEAD24) from LSI to print head. LSI generates print timing and drive time.

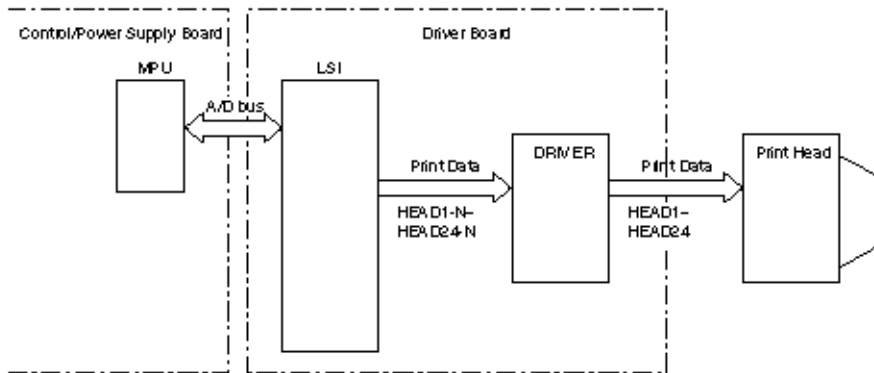

HEAD DRIVE TIMING CHART

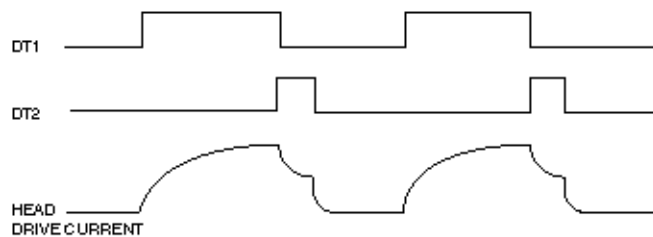

Print Compensation Control

The print compensation can be made as shown below:

- (a) Voltage compensation (See 2.1.8 “Alarm Circuit.”)
- (b) Temperature compensation (See 2.1.8 “Alarm Circuit.”)
- (c) Pin stroke compensation

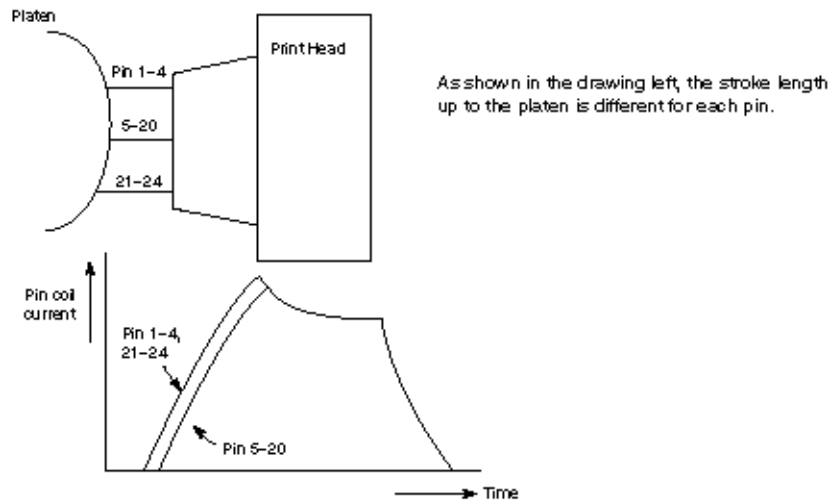

- (d) Simultaneous Compensation of the number of impact pins

The LSI is provided with the compensation table for each pin to make necessary compensation.

Number of impact pins	Few	↔	Many
Drive time	Short	↔	Long

Print Mode Compensation

According to the thickness of the printing medium, the print mode is compensated as shown in the table below:

Head Gap Range	1	2	3	4	5
Print speed	100%	95%	85%	85%	80%
Drive time	Short ← → Long				

(Drive time
lengthens at
each step.)

Copyright 1997, Okidata, Division of OKI America, Inc. All rights reserved. See the OKIDATA Business Partner Exchange (BPX) for any updates to this material. (<http://bpx.okidata.com>)

2.1.06 Space Motor / Line Feed Motor Control

Space Motor Control

The SP motor driver (HA13412) drives the three-phase brushless motor based on the phase signal (SPU, SPV and SPW) and the speed instruction data from the LSI. The MPU can identify the current speed of the space motor by measuring through the LSI the pulse length of the output (ϕA , ϕB) of the slit encoder included in the space motor. By comparing the target speed for each print mode with the actual current speed to change the speed instruction data, the motor speed is accelerated or decelerated to maintain the specified speed for each print mode.

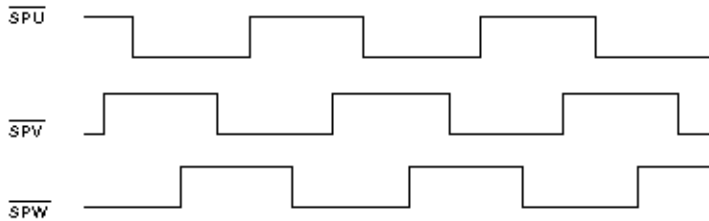

SP Truth Table

HALL AMP INPUT			OUTPUT		
SPU	SPV	SPW	U	V	W
H	H	L	OPEN	L	H
H	L	L	L	OPEN	H
H	L	H	L	H	OPEN
L	L	H	OPEN	H	L
L	H	H	H	OPEN	L
L	H	L	H	L	OPEN

Encoder Disk

In the operation of the spacing motor, the PHASE-A and PHASE-B signals are generated when the encoder disk interrupts the photo sensor.

The LSI divides these edge pulse signals in accordance with the print pitch, and sends the IPT signal to provide dot-on timing and carriage position detection timing.

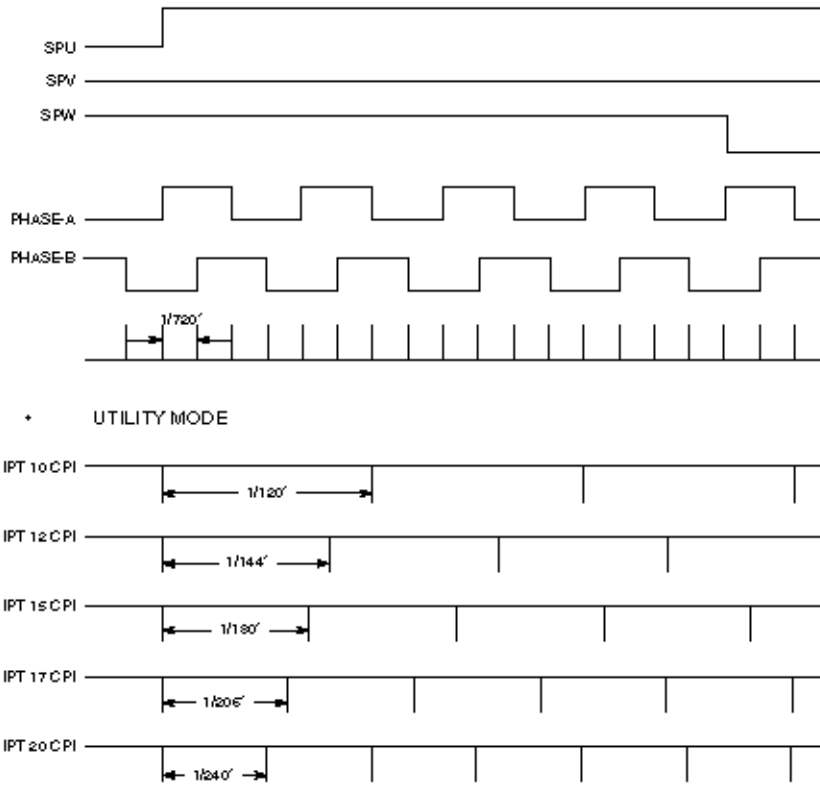

Line Feed Motor Control

The Line Feed motor driver (MTD2005F) drives the Line Feed motor in two-phase or 1-2 phase bipolar, based on the phase changeover data and the output current data from the LSI.

The data from the LSI is processed by a specific register contained in the LF motor driver to measure the overdrive time and to change the phase.

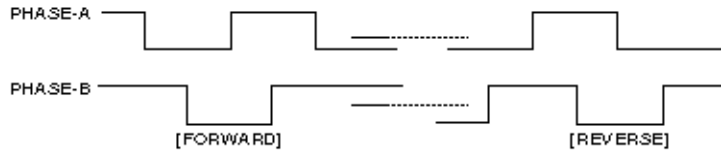

2.1.07 Operation Panel

The clock synchronization OPCLK of LSI is used to input the switch data and output the LED data through the operation panel control LSI (IC1: BU5148S).

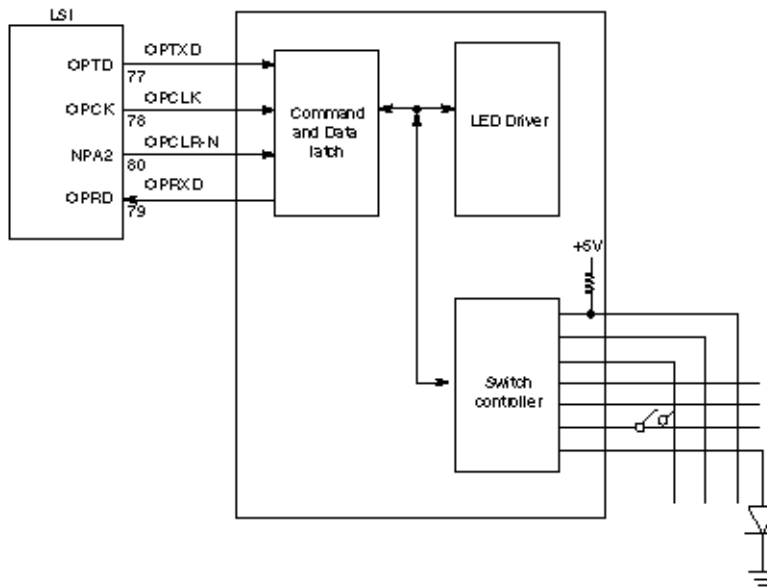

A 2-byte (15 bits + 1 even parity bit) command (OPTXD) is transmitted to the LSI (BU5148S) in synchronization with the OPCLK signal. The LSI decodes this command and when it is found to be legal, returns a 2-byte command response back to the LSI which includes data on Switch information, LED status, receive command ACK/NAK and 1 odd parity bit.

Any transmission errors found cause the command to be reissued after the transmission of the OPCLR-N signal.

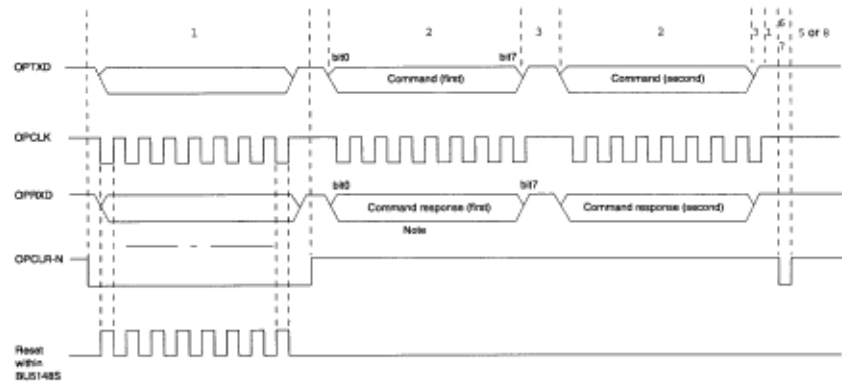
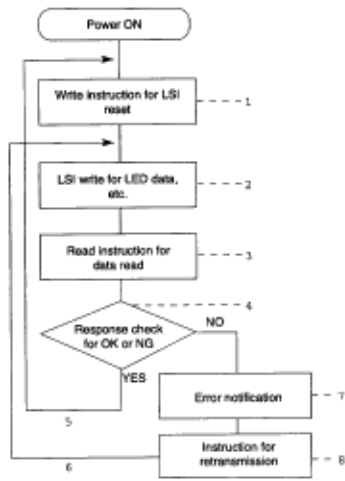

Note: From the illustration above, you can see that the command and the command response are output at the same time. This is because the bit 0 to bit 3 of OPRXD are fixed so that the response can be returned before decoding the command.



Service Guide ML390/ML391 Turbo

Chapter 2 Theory of Operation

2.1.08 Alarm Circuit

Head Drive Time Alarm Circuit

This circuit monitors the drive time using the HDALM signal interlocked with the overdrive signal of each drive circuit.

If the drive time of any drive circuit exceeds the specified time, the drive fault alarm circuit sends an ALARM-N signal to turn on the SCR (SO).

This cause the secondary coil (40V) of the transformer to be short-circuited, causing an overcurrent to flow through the primary coil and making the AC fuse (transformer ASS) open.

Alarm Processing When DC Power is Low

+ 40V is converted into the POWLEV signal (0V to +5V) by R531 and R532 and input into the A/D port of the MPU to control the drive time and the print speed (pass number) of the head.

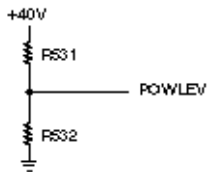

Head Drive Time

The head drive time is lengthened to compensate for the amount of voltage drop by monitoring the POWLEV signal once every 500 m sec. to control and maintain the impact necessary for each printing pin at the fixed value.

Print Speed

Voltage, +40V	Pass number	Print speed
38V or more	1 Pass	100%
25V to 37V	1 Pass	100-30%
25V or less	1 Pass	30%

Head Overheat Alarm

The voltage of the output TSD signal of the thermistors, one of which is contained in the print head and the other in the print head driver, is monitored by the CPU/AD port to control the voltage.

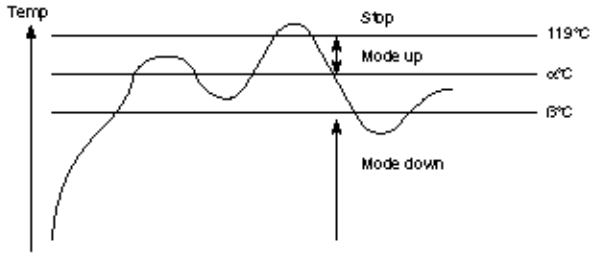

Mode and Print Control

Mode	Speed	Pass	Direction	
1	100%	1	Bi	
2	85%	1	Bi	
3	70%	1	Bi	
4	55%	1	Bi	
5	40%	1	Bi	
6	30%	1	Bi	1.5 Sec Stop
7	Stop			

- When the temperature is between $\alpha^{\circ}\text{C}$ and 119°C , the mode switches sequentially to higher level. When the temperature falls below $\beta^{\circ}\text{C}$, the mode switches to lower level.
- When the temperature exceeds 119°C , printing will stop.
- When temperature gradient is steep, higher mode shall be specified directly.

2.1.09 Power Supply Circuit

This power supply circuit supplies the +5VDC, +8VDC, +40VDC, 10VAC.

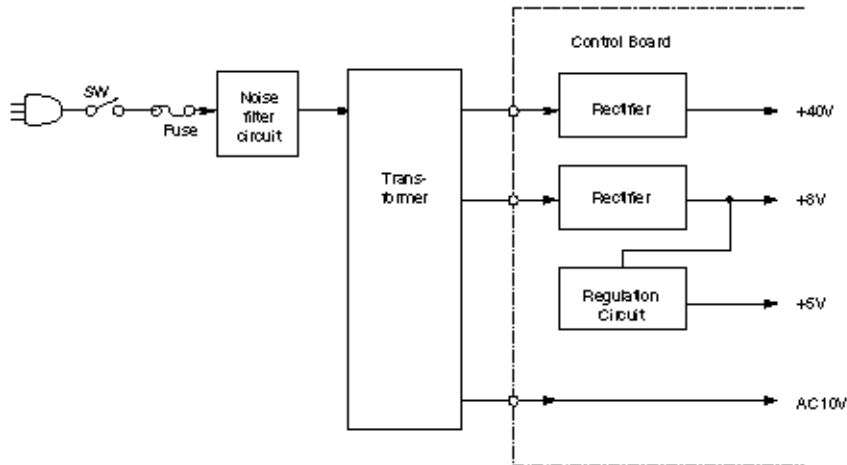

The uses of output voltages and signals are described below.

Voltage/signal	Use
+5V	Logic IC/LED drive voltage
+8V	Serial interface line voltage and SP motor driver
+ 40V	Printhead, LF motor drive voltage, SP motor drive voltage
AC 10V	Option board

2.2.01 Printhead Mechanism and Operation

Refer to Figure 2-2 (shown below)

The printhead is a spring charged 24-pin driving head using a permanent magnet. It is attached to the carriage, which moves in parallel with the platen. Electrically, this unit is connected to the control circuits through the control board.

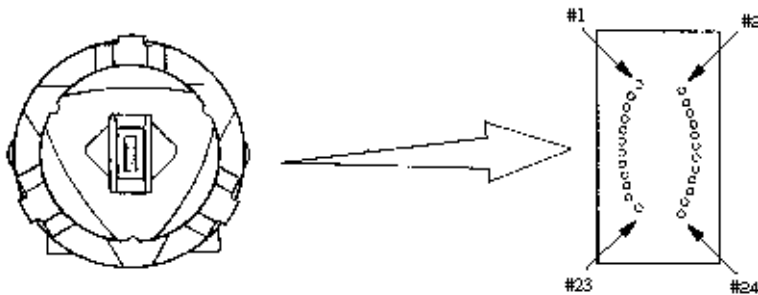

Figure 2-2 Arrangement of the head pins, View from the tip of the printhead

(1) Printhead Configuration

The printhead is composed of the following parts:

- (a) Wire guide
- (b) Spring assembly (Wire, Armature, Spring, Yoke, Spacer)
- (c) Magnet assembly (Magnet, core, coil, Yoke)
- (d) Printed circuit board
- (e) Fin

(2) Operation of Printhead

Refer to Figure 2-3 (shown below)

- (a) When the printhead is idle, the armature is attracted by a permanent magnet and the spring fixing the armature is compressed. The print wires fixed to each armature are thus concealed under the wire guide.
- (b) When a signal for a character to be printed is detected, a current flows through the coil. When the coil is activated, the magnetic flux (caused by the permanent magnet between the armature and the core) is canceled to eliminate the attraction force. The armature is driven in the direction of the platen by the force of the armature spring. The print wire fixed to the armature

protrudes from the tip of the wire guide, strikes the paper through the ribbon and prints a dot on the paper.

(c) After the character has been printed, the armature is magnetically attracted again and the print wires are again concealed under the wire guide.

A thermistor in the printhead prevents burning caused by over-heating of the coil during extended continuous bi-directional printing. When the temperature of the coil exceeds a pre-determined limit (about 119°C) the control circuit detects a thermistor signal. Printing will then be intermittent or stop completely until the coil temperature falls below the limit value.

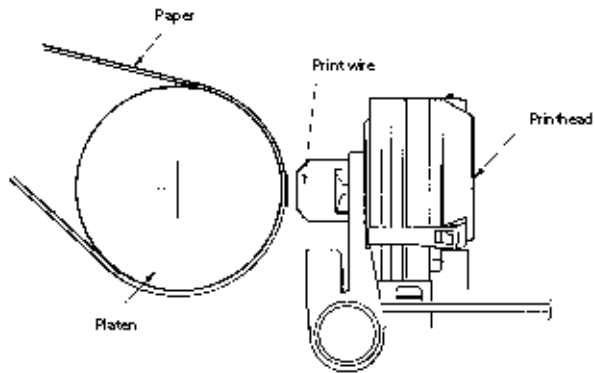

(1) When printing

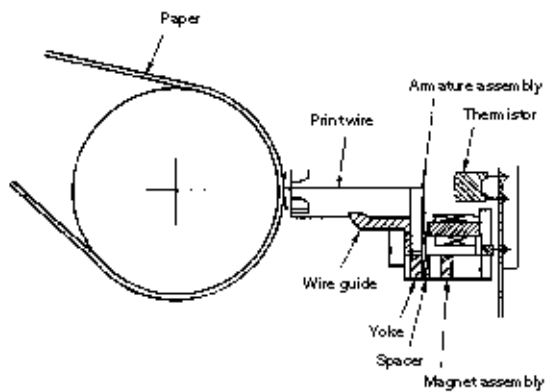

(2) When not printing

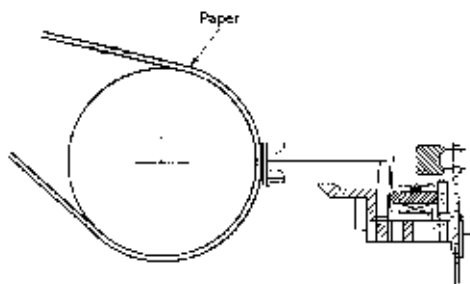

Figure 2-3



Copyright 1997, Okidata, Division of OKI America, Inc. All rights reserved. See the OKIDATA Business Partner Exchange (BPX) for any updates to this material. (<http://bpx.okidata.com>)

2.2.02 Spacing Operation

Refer to Figure 2-4 (shown below).

The spacing mechanism consists of a carriage shaft mounted in parallel with the platen, and a carriage frame that moves along the shaft. It is driven by a DC motor mounted on the bottom of the carriage frame. Items included in the spacing mechanism are as follows:

- (a) DC motor with motor gear
- (b) Carriage frame (stationary yoke and motor driver board included)
- (c) Carriage shaft
- (d) Space rack
- (e) Sensor
- (f) Encoder disk

(1) Spacing Operation

The carriage frame, on which the printhead and space motor are mounted, moves along the carriage shaft in parallel with the platen. When the spacing motor rotates counterclockwise, the driving force is transmitted to the motor gear. As the motor gear rotates, the carriage moves from left to right.

Mechanically, it is designed in such a way that for every revolution of the DC motor, the carriage frame moves 0.8 inch (20.32 mm).

At the same time the encoder disk rotates together with the motor and passes the sensor. The position of the carriage frame can be determined by counting the interrupts detected by the sensor.

In the same way, the rotation of the space motor can be recognized and controlled by measuring the cycle of interrupts detected by the sensor.

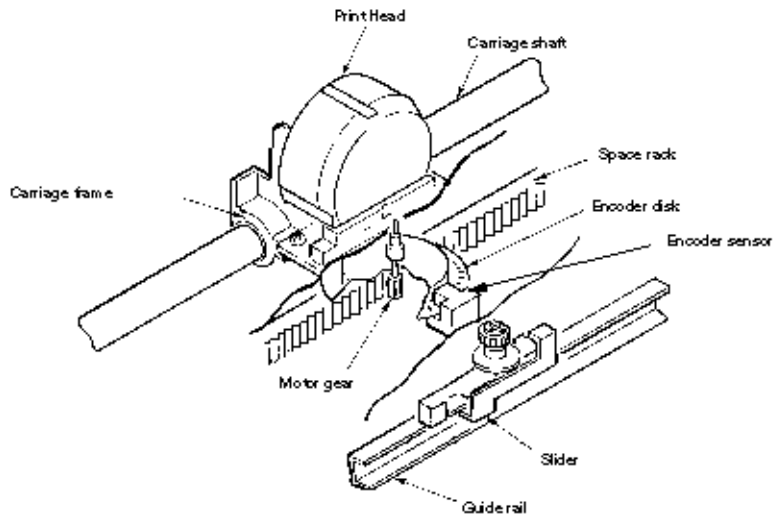

Figure 2.4

Copyright 1997, Okidata, Division of OKI America, Inc. All rights reserved. See the OKIDATA Business Partner Exchange (BPX) for any updates to this material. (<http://bpx.okidata.com>)

2.2.03 Head Gap Adjusting

Refer to Figure 2-5 (shown below).

The head gap adjusting lever moves back and forth to tilt the carriage frame, altering the gap between the printhead and the platen.

The adjusting screw, which is connected to the adjusting gear rotates when the adjusting lever is moved creating a fine gap adjustment. If the adjusting gear is pushed down, the adjusting screw can be turned with a screw driver to change the coarse gap adjustment.

When the adjusting lever is set to range $i \sim f$ the contact which is attached to the under side of the carriage cover will connect with the contact of the space motor PC board. The printer will reduce the printing speed automatically to ensure that adequate printing pressure is maintained for multipart paper.

And, the adjusting cam adjusts the headgap toward left and right side in accordance with the guide rail up and down as a position of the left end of it.

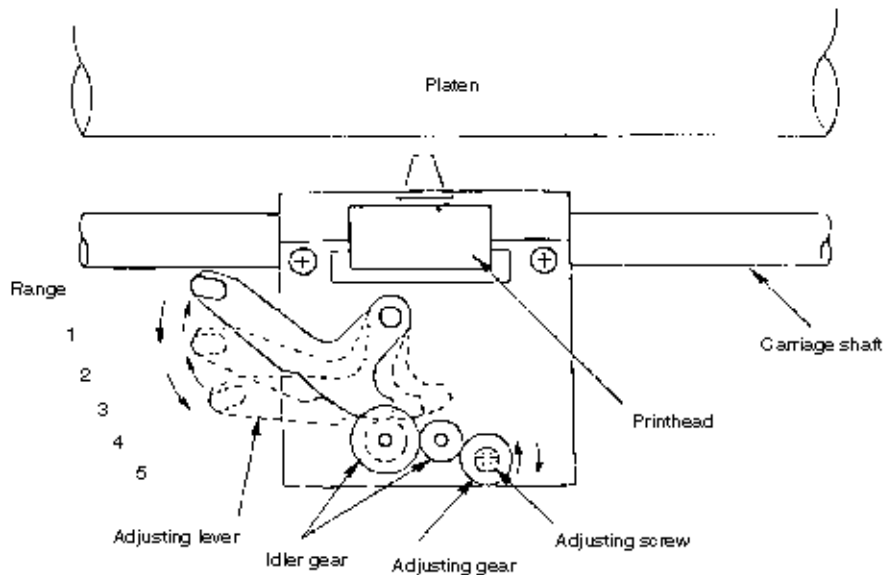

Range from 5 to 1

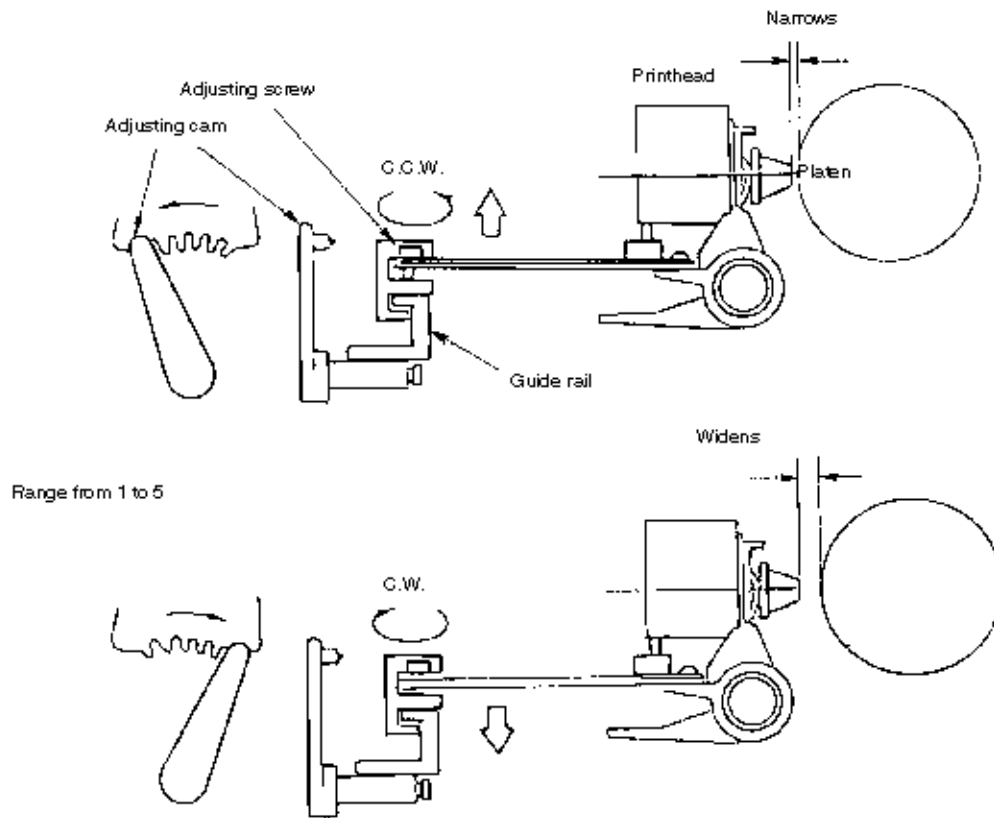

Figure 2-5

Copyright 1997, Okidata, Division of OKI America, Inc. All rights reserved. See the OKIDATA Business Partner Exchange (BPX) for any updates to this material. (<http://bpx.okidata.com>)

2.2.04 Ribbon Drive

Refer to Figure 2-6 (shown below).

The ribbon driver mechanism moves the ribbon in synchronization with the space motor operation.

The ribbon drive mechanism consist of the following items:

- (a) Ribbon drive gear assembly
- (b) Ribbon gear (space motor)
- (c) Ribbon cartridge

(1) Ribbon Cartridge

An endless ribbon with a single direction feed is used. Ink is supplied from an ink tank, which is built in to the ribbon cartridge.

(2) Ribbon Feed Operation

When the space motor is activated, the ribbon gear rotates. The rotation is transmit-
ted via the ribbon drive gear assembly to the drive gear in the ribbon cartridge, thus
moving the ribbon.

The feed direction of the ribbon is maintained by switching the rotational direction of
the gears in the ribbon drive gear assembly. This ensures ribbon movement when
bidirectional printing is used.

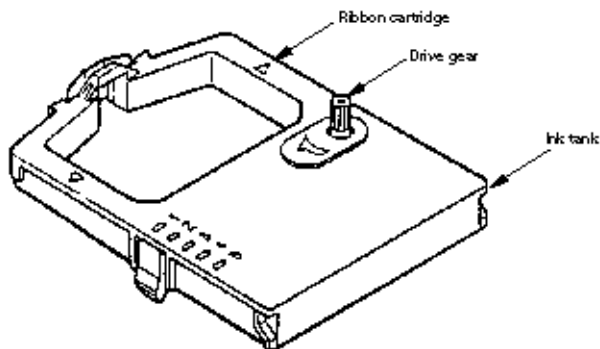

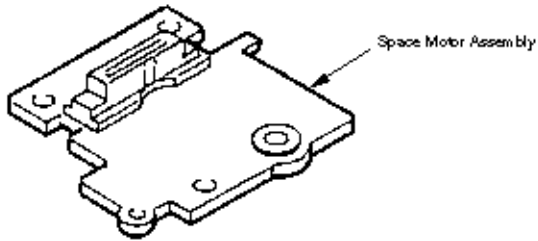
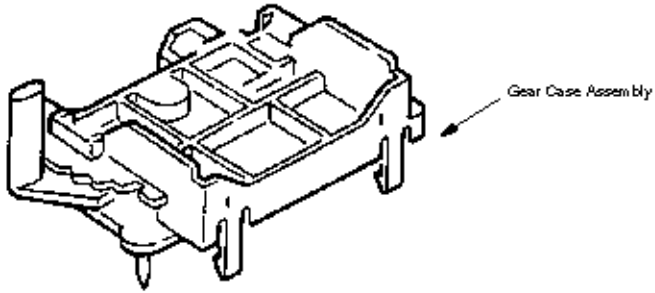

Copyright 1997, Okidata, Division of OKI America, Inc. All rights reserved. See the OKIDATA Business Partner Exchange (BPX) for any updates to this material. (<http://bpx.okidata.com>)

2.2.05 Paper Feed Operation

Feeding of the paper is performed by turning the platen and the pin tractor, which is driven by the Line Feed Pulse Motor.

The paper feed mechanism is made up of the items listed below.

- (a) Pulse motor with gears
 - (b) Decelerating gear
 - (c) Platen
 - (d) Tractor feed unit
 - (e) Pressure roller
-

Cut Sheet and Continuous Forms Switching Mechanism

Refer to Figure 2-8 (below).

Three different paper paths can be selected and set by the change lever.

(a) TOP (for cut sheet)

When the cut sheet is used in the manual mode or fed by the CSF (option), set the change lever at the position marked TOP.

Operation

The driving force of the platen gear (R) is transmitted to the idle gear by setting the change lever to the TOP position. However, this causes the idle gear to be disengaged from the change gear, leaving it free.

At this time, the pressure rollers (at the rear and the front) are pressed securely to the platen to feed the cut sheet. At the same time, the switch lever positions between the rear switch and bottom switch, to confirm to the control board that you are in the cut sheet mode.

In the cut sheet mode, the control board automatically feeds the sheet up to the print start position after pausing for the wait time stored in the menu.

(b) REAR (Continuous forms from push tractor)

When the change lever is set to REAR position, the change gear is engaged with the idle gear and the tractor gear to transmit the rotation of the platen to the push tractor shaft, and the continuous forms is fed from the push tractor. At the same time, the switch lever turns on the rear switch, to confirm to the control board that you are in the continuous forms mode.

(c) BOTTOM (Continuous forms from bottom feeder) (option)

When the change lever is set in the BOTTOM position, the rotation of the platen is transmitted to the drive gear of the bottom tractor feed unit through the idle gear to feed the paper which has been set in the bottom tractor feed. At the same time, the switch lever turns on the bottom switch, to confirm to the control board that you are in the continuous forms mode.

Figure 2-8

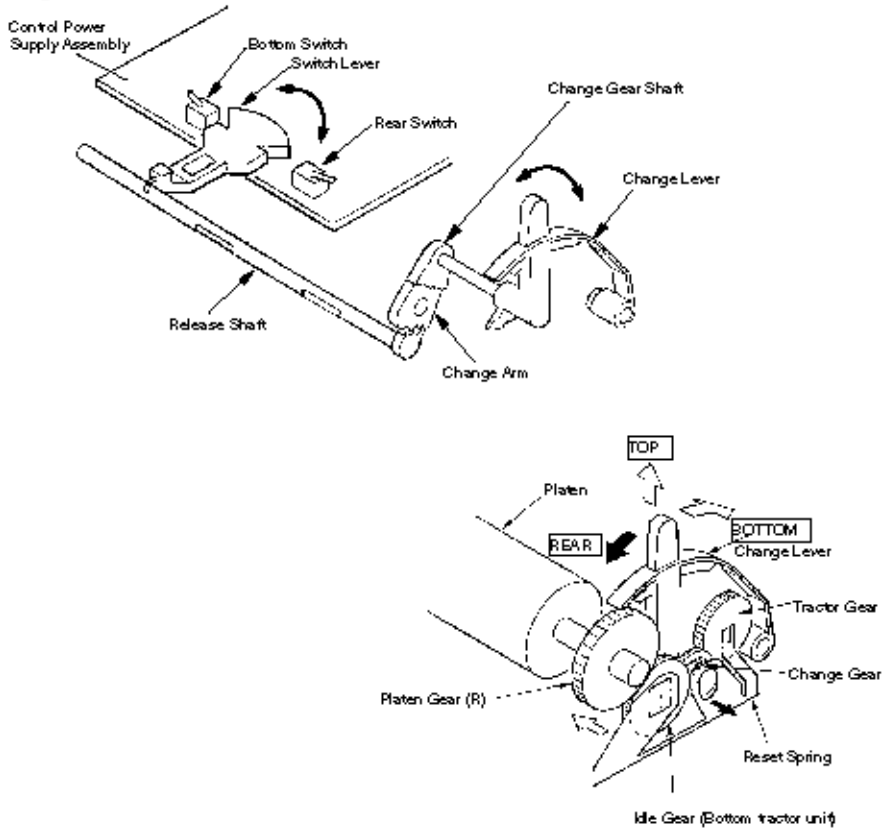

Correlation in Mechanism

Mechanism Lever Position	Rear Switch	Bottom Switch	Idle Gear	Change Gear	Tractor Gear	Sheet Insertion
TOP	OFF	OFF	Rotate	Stop	Stop	Manual/ automatic CSF: Operation SW or instruction
REAR	ON	OFF	Rotate	Rotate	Rotate	+ Operation SW or + instruction
BOTTOM	OFF	ON	Rotate	Rotate	Stop	+ Operation SW or + instruction

(2) Cut-sheet feeder operation

Refer to Figure 2-9 (below).

The pulse motor used for the paper feed mechanism is mounted on the left of the frame, and the rotation of the motor is transmitted through decelerating gears (LF idle gear, platen gear) to the platen. When using cut-sheet paper, the change lever must be in the TOP position to grab the paper, while disengaging the push tractor.

When the change lever is set to the TOP position, the cut sheet is automatically fed in up to the print start position after pausing for the wait time stored in the menu.

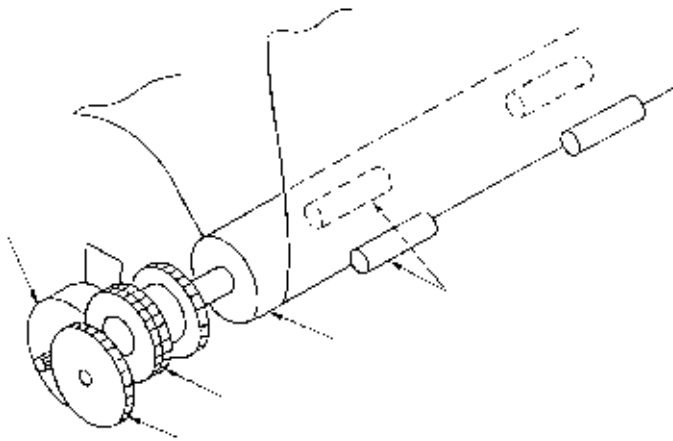

(3) Continuous Forms Operation (Rear)

See Figure 2-10 (below).

The force transmitted to the platen, rotates the tractor gear through platen gear, the idler gear and the change gear. The rotation of the tractor gear makes the pin tractor belt rotate through a sheet feeder shaft, feeding the continuous forms.

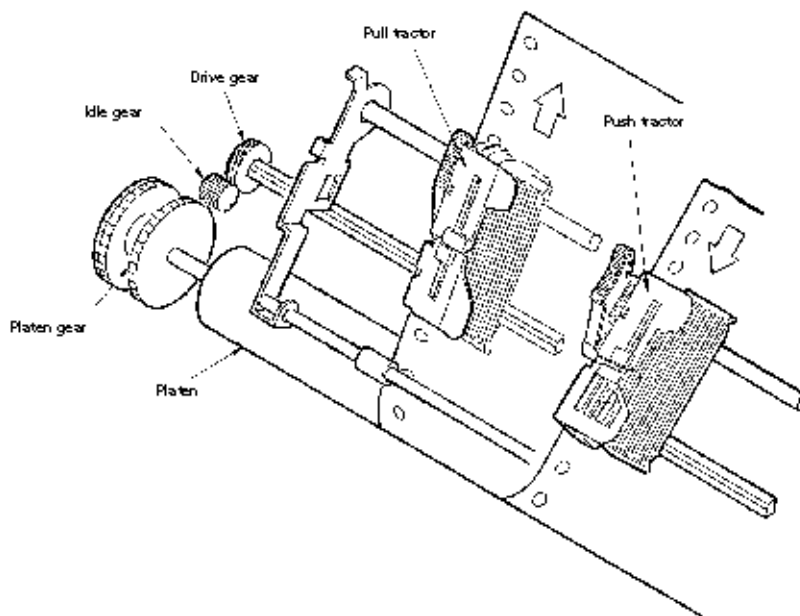

Figure 2-11

(4) Push and pull tractor mechanism (Option)

Refer to Figure 2-11 (below).

This mechanism consist of an optional pull tractor and a standard push tractor mechanism. This mechanism can perform forward and reverse feed by setting continuous forms to the push tractor and pull tractor.

The rotation of the platen is transmitted to the push tractor and the pull tractor. Continuous forms are fed by these two tractors at the same time.

To remove slack from the sheets, set the sheets according to the following procedure when using the push and pull tractors.

- 1 Set the change lever to the REAR position (setting the forms to the push tractor to feed).
- 2 Set the paper, which is fed in front of the platen, to the pull tractor.
- 3 Set the change lever to the TOP position and feed paper using the platen knob.
- 4 If paper slack is removed, set the change lever to the REAR position.

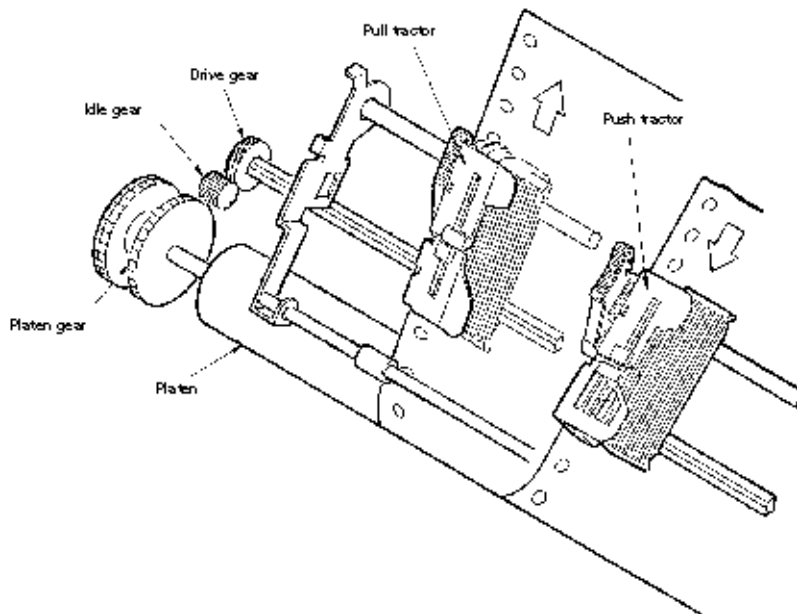

Figure 2-11

Copyright 1997, Okidata, Division of OKI America, Inc. All rights reserved. See the OKIDATA Business Partner Exchange (BPX) for any updates to this material. (<http://bpx.okidata.com>)

(5) Pull tractor mechanism (option)

Refer to Figure 2-12 (below).

Bottom feed of continuous forms is possible only when an optional pull tractor unit is installed.

The rotation of the platen is transmitted to the idle gear of the pull tractor unit through the platen gear at the left end of the platen. The rotation of the idle gear is transmitted to the drive gear, and continuous forms are fed by the pull tractor being rotated through the sheet feeder shaft.

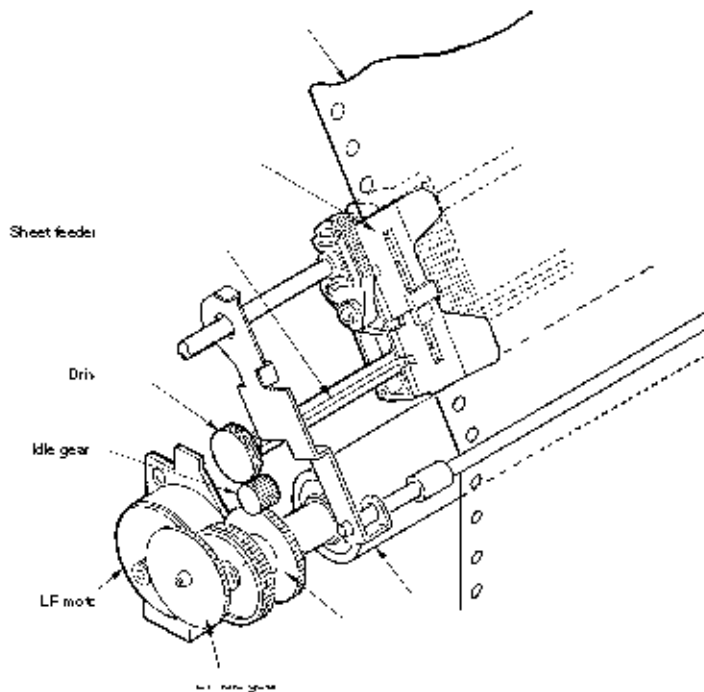

Figure 2-12

(6) Bottom Push Feed Operation (Option)

Refer to Figure 2-13 (below).

The bottom push feed of the continuous forms is possible only when the bottom tractor feed unit is installed.

When the platen rotates, the rotational force of the platen is transmitted through the tractor idle gear and the tractor change gear to the tractor drive gear of the bottom push tractor, and the sheet of paper is fed in to the print start position.

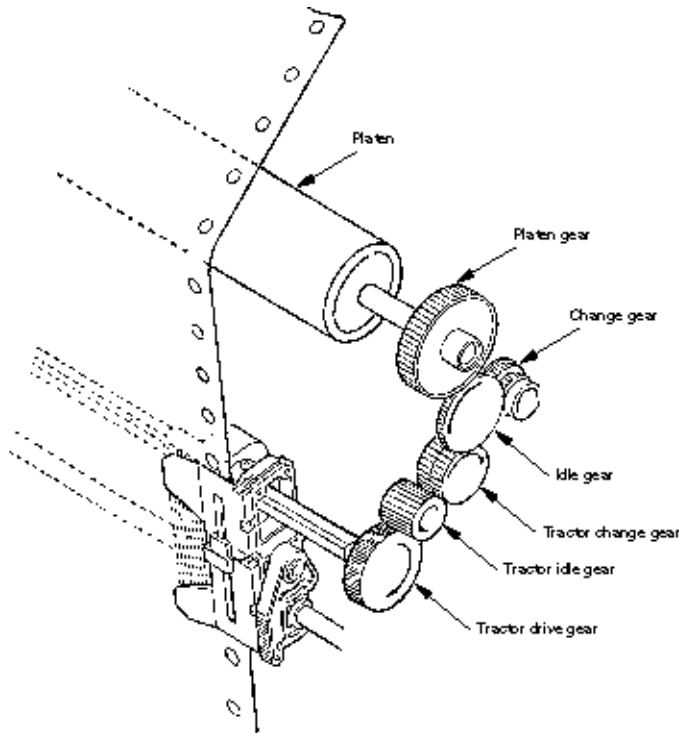

Figure 2-13

(7) Paper Clamp Mechanism

Refer to Figure 2-14 (below).

When setting the change lever to the BOTTOM, TOP or REAR position, the operation of the front release gear arm changes according to the position of the release cam. And at the same time, the position of the cam installed to the front release gear shaft changes, and the open and close of the pressure roller.

Position of change lever	Open or close of front pressure roller	Open or close of rear pressure roller
BOTTOM	OPEN	OPEN
TOP	CLOSE	CLOSE
REAR	OPEN	OPEN

TOP

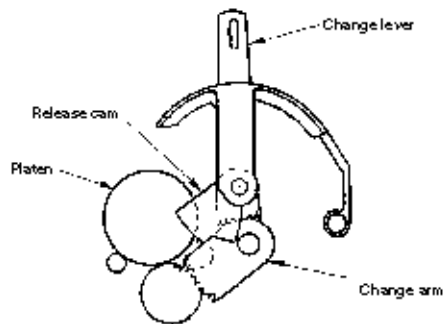

BOTTOM

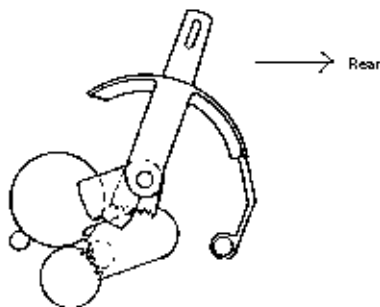

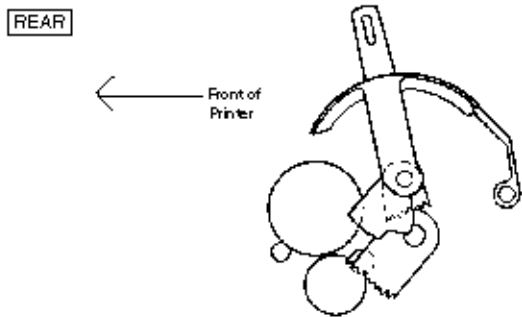

Figure 2-14

Copyright 1997, Okidata, Division of OKI America, Inc. All rights reserved. See the OKIDATA Business Partner Exchange (BPX) for any updates to this material. (<http://bpx.okidata.com>)

2.2.06 Paper Detection Mechanism

Refer to Figure 2-15.

The three paper detection types are listed below.

1. Cut Sheet Detection
2. Rear Feed Detection
3. Bottom Feed Detection.

Cut Sheet Detection

When the cut sheet is inserted, the point A is pushed backward and the paper near end lever B rotates counter clockwise (CCW).

At this time, the rear sensor lever rotates counterclockwise (CCW), the rear sensor lever and pulls out of the rear and top paper end sensor to detect that the sheet is provided.

The procedure for the paper end is made in the reverse order, that is, its detection is performed when the paper end sensor is blocked.

Rear Feed Detection

When the paper is fed from the push tractor, the point B is pushed to the front side and the paper near end lever A rotates clockwise (CW). At this time, the rear sensor lever rotates counterclockwise (CCW), and pulls out of the rear and top paper end sensor to detect that the paper is provided.

The procedure for the paper end is made in the reverse order, that is, its detection is performed when the rear sensor lever intercepts the sensor.

Bottom Feed Detection

When the paper is fed from the bottom, the point C rotates clockwise (CW). When the bottom sensor lever rotates clockwise (CW), it pulls out of the bottom paper end sensor to detect that the paper is provided.

The procedure for the paper end is made in the reverse order, that is, its detection is performed when the bottom sensor lever intercepts the sensor.

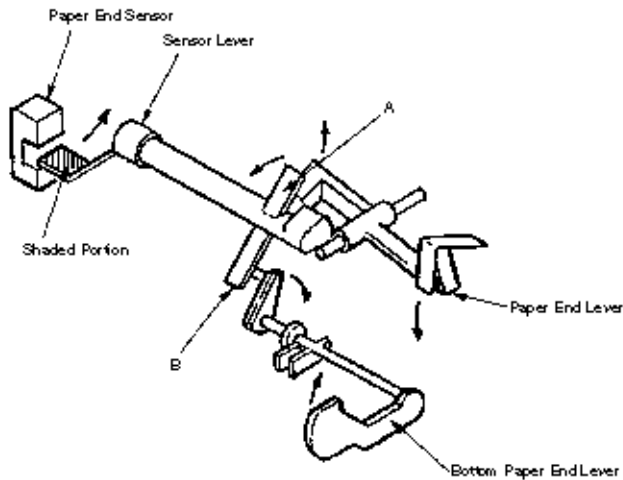

Figure 2-15

Top Line Print Mechanism

Refer to Figure 2-16 (below)

The top edge of the sheet is protected by the ribbon protector so that it can stop at a position near to the print head (0 tear off position) to start printing at the top end of the sheet, without causing the sheet to crumple or curl up.

The printing starts at the front end of the sheet, and continues uni-directionally until the front end of the sheet gets to the inside of the pull up roller cover.

After that, that printing continues bi-directionally.

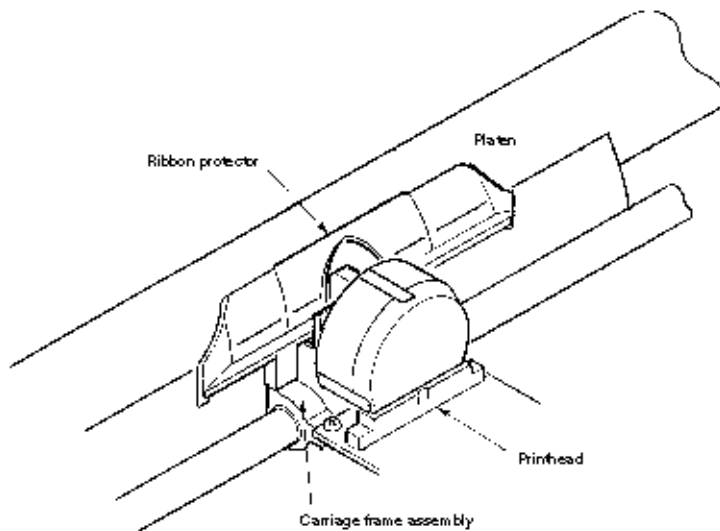

Figure 2-16

Copyright 1997, Okidata, Division of OKI America, Inc. All rights reserved. See the OKIDATA Business Partner Exchange (BPX) for any updates to this material. (<http://bpx.okidata.com>)

2.2.07 Automatic Sheet Feed

This function is used to feed in the sheet automatically up to the print start position when the cut sheet or the continuous forms is used.

[Operational procedure]

When Using Cut Sheet

- 1) Set the change lever to the TOP position. (See Figure 2-17 below.)
- 2) Insert a sheet of paper between the platen and the paper shoot.
- 3) After the lapse of time selected by the "wait time" in the menu, the LF motor starts its operation to feed the sheet of paper up to the print position.
- 4) When the default is selected, the sheet of paper is feed in up to the position 0.35 inches (first dot position) from the upper end of the sheet. However, the 0 tear off mechanism allows the printing at the front end of the sheet by changing the TOF position.

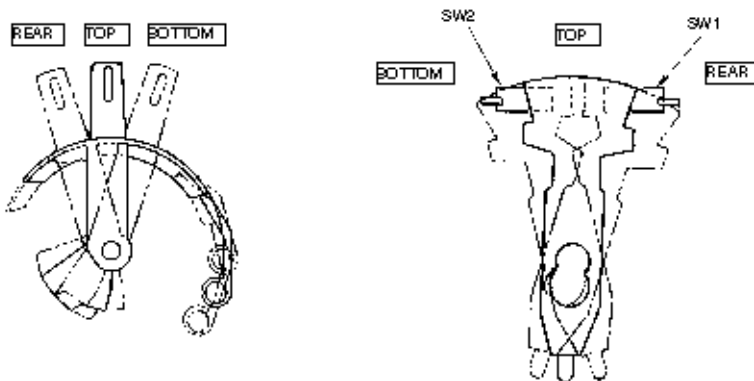
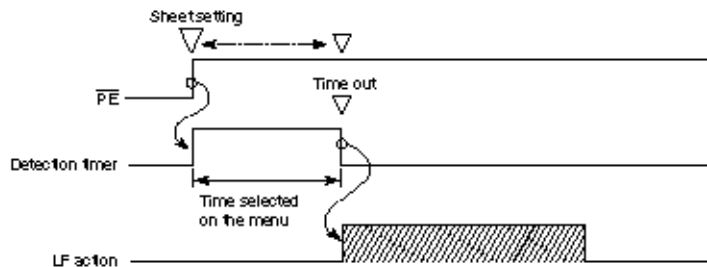
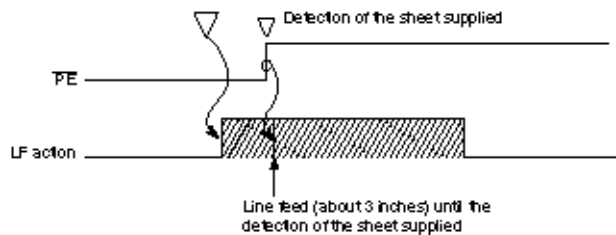

Figure 2-17

When Using Continuous Forms

- 1) Set the change lever either to the rear side or the bottom side position. (See Figure 2-17 above.)
- 2) Set a sheet of paper either to the push tractor or the bottom tractor.
- 3) Press the "FF/LOAD" switch.
- 4) The LF motor starts its operation to feed the paper up to the print start position.
- 5) The paper is fed in up to the TOF position (Factory default: 0.35 inches from the top).

Push down the "FF/LOAD" switch.



When the "FF/LOAD" switch is pushed down, the LF motor feeds in the sheet about 3 inches. When the LF motor completes the operation and the sheet has not been fed in, the feeding operating operation becomes, ineffective, thus resulting in the feeding jam.

Copyright 1997, Okidata, Division of OKI America, Inc. All rights reserved. See the OKIDATA Business Partner Exchange (BPX) for any updates to this material. (<http://bpx.okidata.com>)



Service Guide ML390/ML391 Turbo

Chapter 2 Theory of Operation

2.2.08 Paper Park Function (Continuous Forms)

Continuous forms which have been inserted can be reversed automatically by using the "PARK" button on the operation panel.

- 1) Press the "PARK" button on the operation panel.
- 2) Reverse LF is started and paper is fed in reverse until paper end occurs or 19 inches maximum have been fed.
- 3) The paper is fed in reverse, to leave the paper on the push-tractor or bottom-tractor.

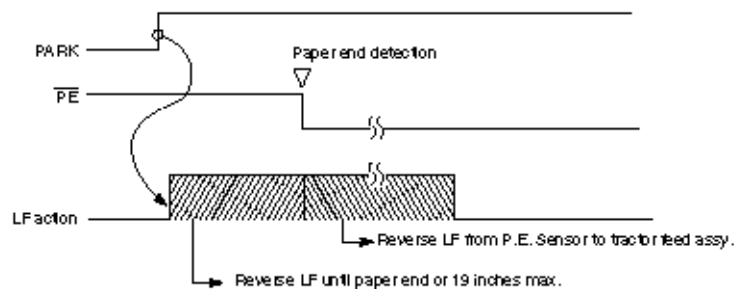

Alarm LED lights up when P.E. is not detected after 19 inches reverse feeding.

Operator can press SEL key to turn off the ALARM LED then press PARK key to continue park function.

This operation is required when the length of paper for parking is more than 19 inches.



Service Guide ML390/ML391 Turbo

Chapter 3 Assembly/Disassembly

ASSEMBLY/DISASSEMBLY

This section explains the procedures for removing and installing various assemblies and units in the field.

Description is mainly limited to the removal procedure; installation should basically be performed in the reverse sequence of the removal procedure.

Copyright 1997, Okidata, Division of OKI America, Inc. All rights reserved. See the OKIDATA Business Partner Exchange (BPX) for any updates to this material. (<http://bpx.okidata.com>)

3.1 Precaution for Parts Replacement

- (1) Remove the AC cable and the interface cable before disassembling or assembling.
 - (a) Turn off the AC power switch. Remove the AC input plug of the AC cable from the receptacle. Remove the AC cable from the inlet on the printer.
 - (b) To connect the AC cable again, connect it to the inlet on the printer first, then insert the AC input plug into a receptacle.
- (2) Do not disassemble the printer as long as it is operating normally.
- (3) Do not remove unnecessary parts, and limit the disassembly area as much as possible.
- (4) Use the designated service tools.
- (5) Carry out disassembly in the prescribed sequence; otherwise, damage to the parts may result.
- (6) It is advisable to temporarily install screws, snap rings and other small parts in their original positions to avoid losing them.
- (7) Whenever handling the microprocessors, ROM, RAM IC chips and boards, do not use gloves which may cause static electricity.
- (8) Do not place the printed circuit board directly on the equipment or on the floor.
- (9) If adjustment is specified in the middle of installation, follow the instructions.

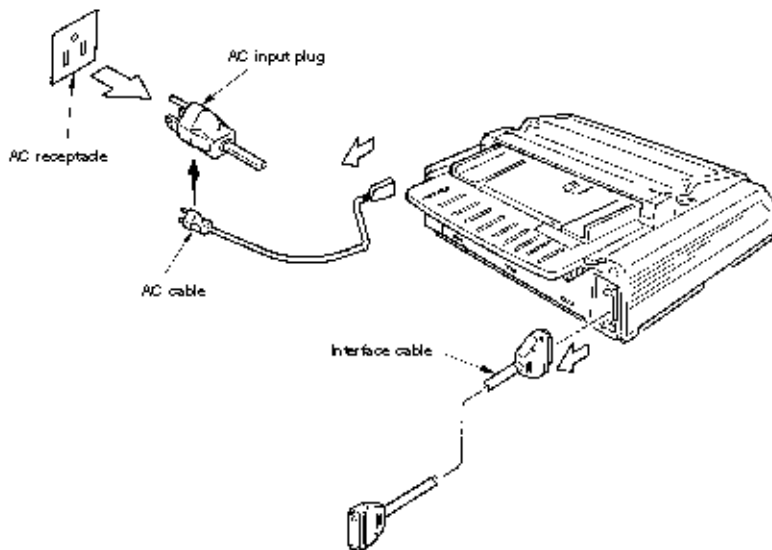

Copyright 1997, Okidata, Division of OKI America, Inc. All rights reserved. See the OKIDATA Business Partner Exchange (BPX) for any updates to this material. (<http://bpx.okidata.com>)









Service Guide ML390/ML391 Turbo

Chapter 3 Assembly/Disassembly

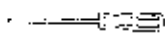
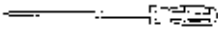
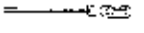
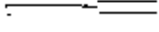
3.2 Service Tools

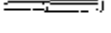
Table 3.1 lists the tools necessary for replacing printed circuit boards and parts of units in the field.

Table 3.1 Service tools

No.	Service Tool	Qty	Use	Remarks
1	 No. 1-100 Phillips screwdriver	1	Screws 2.6 mm	
2	 No. 2-200 Phillips screwdriver	1	Screws 3-5 mm	
3	 No. 3-100 screwdriver	1		
4	 Spring hook	1		
5	 J-YX4025-83335-3	1	Head gap adjustment	
6	 Volt/ohmmeter	1		
7	 Feeler gauge	1	Head gap adjustment	
8	 Pliers	1		
9	 No. 5 rippers	1		
10	 1.1 lbs (500 g) bar pressure gauge	1		



Service Guide ML390/ML391Turbo

Chapter 3 Assembly/Disassembly

3.3 Disassembly/Reassembly Procedure

This section explains the assembly replacement procedures according to the following disassembly system.

Parts Layout

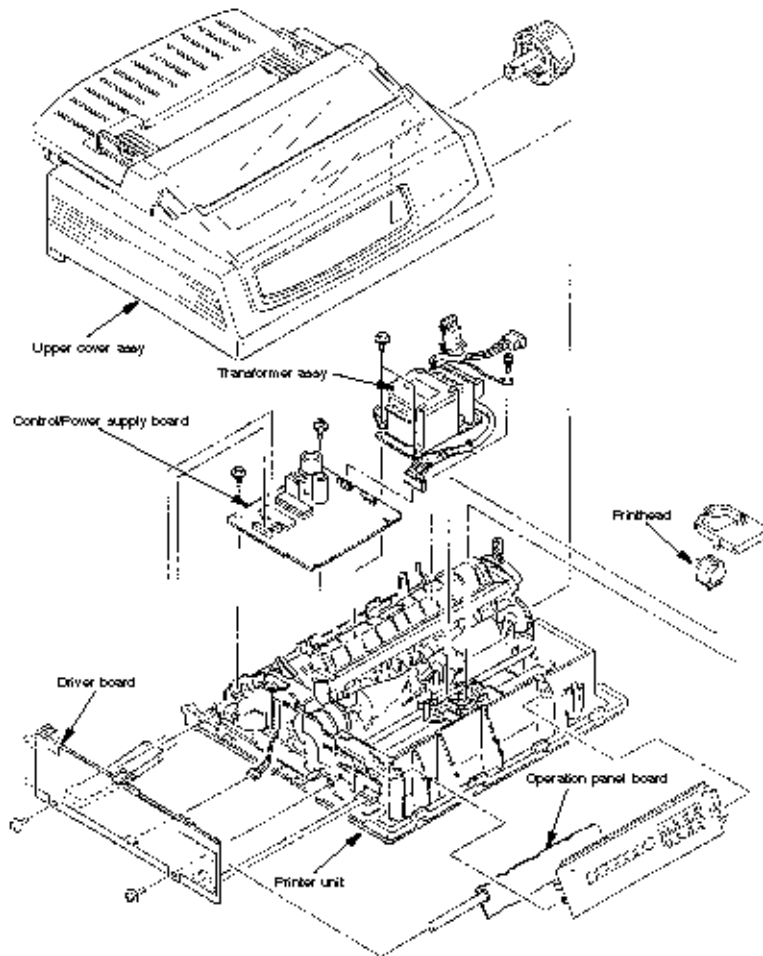

Copyright 1997, Okidata, Division of OKI America, Inc. All rights reserved. See the OKIDATA Business Partner Exchange (BPX) for any updates to this material. (<http://bpx.okidata.com>)



Service Guide ML390/ML391 Turbo

Chapter 3 Assembly/Disassembly

How to Change Parts

This section explains how to change parts and assemblies appearing in the disassembly diagram below.

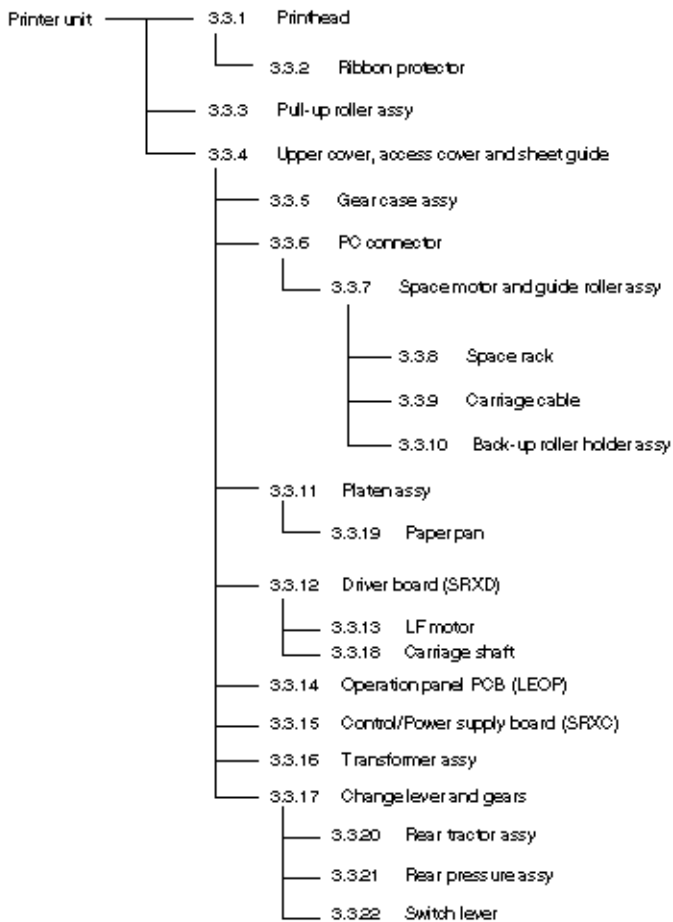

3.3.01 Printhead

- (1) Open the access over.
- (2) Pull up and rotate the head clamp 1 to unclamp the printhead 2 as shown fig. 3.3.1 (see below).
- (3) Disconnect the printhead 2 from PC connector 3.
- (4) To install, follow the removal steps in the reverse order.

Notes on Installation:

Important:

Before inserting the printhead, note that there is a shim on the carriage frame (4), which hangs over the platen side of the frame. Be sure to replace the shim correctly. Improper positioning of this shim will severely affect the printhead gap and therefore affect print quality.

- (1) Insert the printhead 2 into the PC connector 3 while pushing it against the carriage frame 4.
- (2) The head clamp 1 must surely be sandwiched between printhead 2 and carriage frame 4 as shown fig. 3.3.2.
- (3) Be sure to check the gap between platen and printhead (see 4).
- (4) Be careful not to touch the print head while it is very hot.

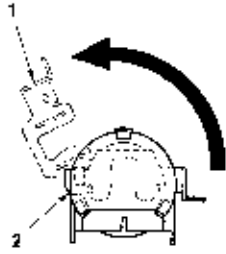

Figure 3.3.1

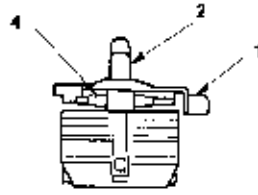
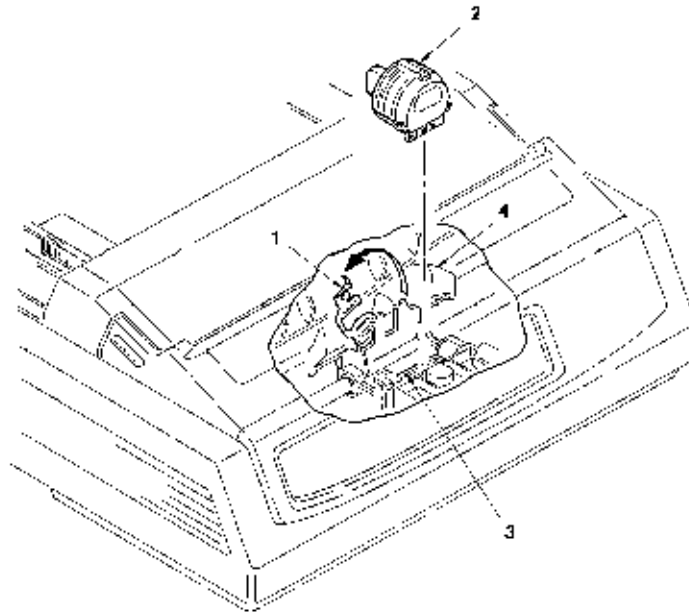

Figure 3.3.2



Copyright 1997, Okidata, Division of OKI America, Inc. All rights reserved. See the OKIDATA Business Partner Exchange (BPX) for any updates to this material. (<http://bpx.okidata.com>)

3.3.02 Ribbon Protector

- (1) Remove the printhead (see 3.3.1).
- (2) Open the pull-up roller cover 1.
- (3) Raise and remove the ribbon protector 2.
- (4) To install, follow the removal steps in the reverse order.

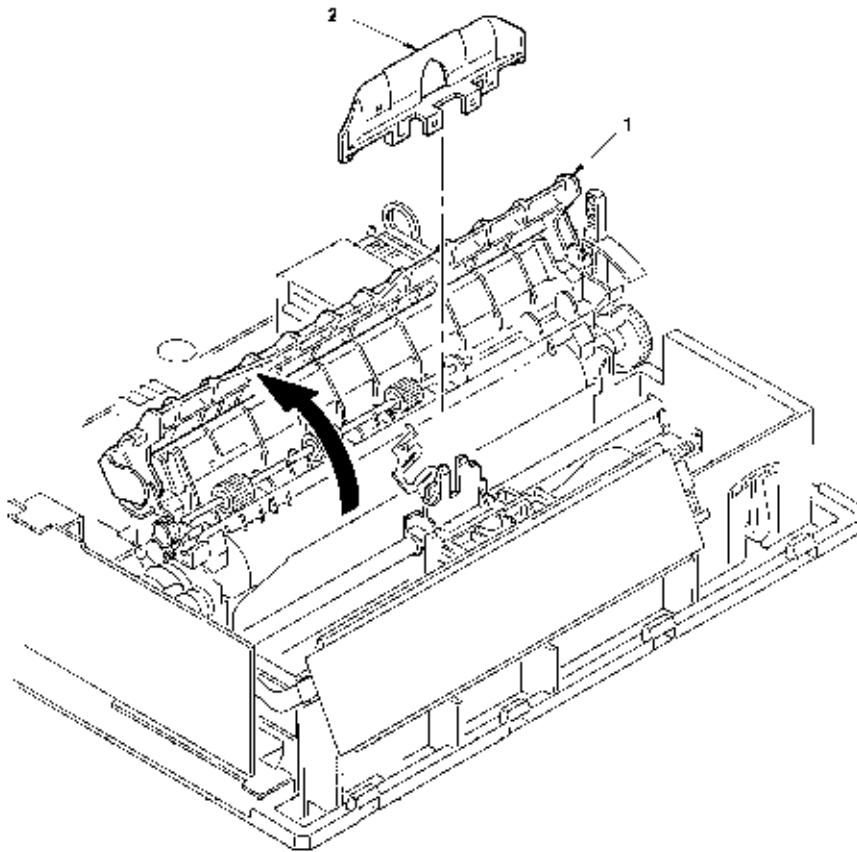

3.3.03 Pull-up Roller Assy

- (1) Open the access cover 1.
- (2) Lift up the sheet guide Assy 4 to remove.

Note: Please do after always remaining the sheet guide Assy 4 when the pull-up roller Assy 2 is installed and removed.

- (3) Tilting the pull-up roller Assy 2 toward the front, remove from the shaft of platen Assy 3.
- (4) To install, follow the removal steps in the reverse order.

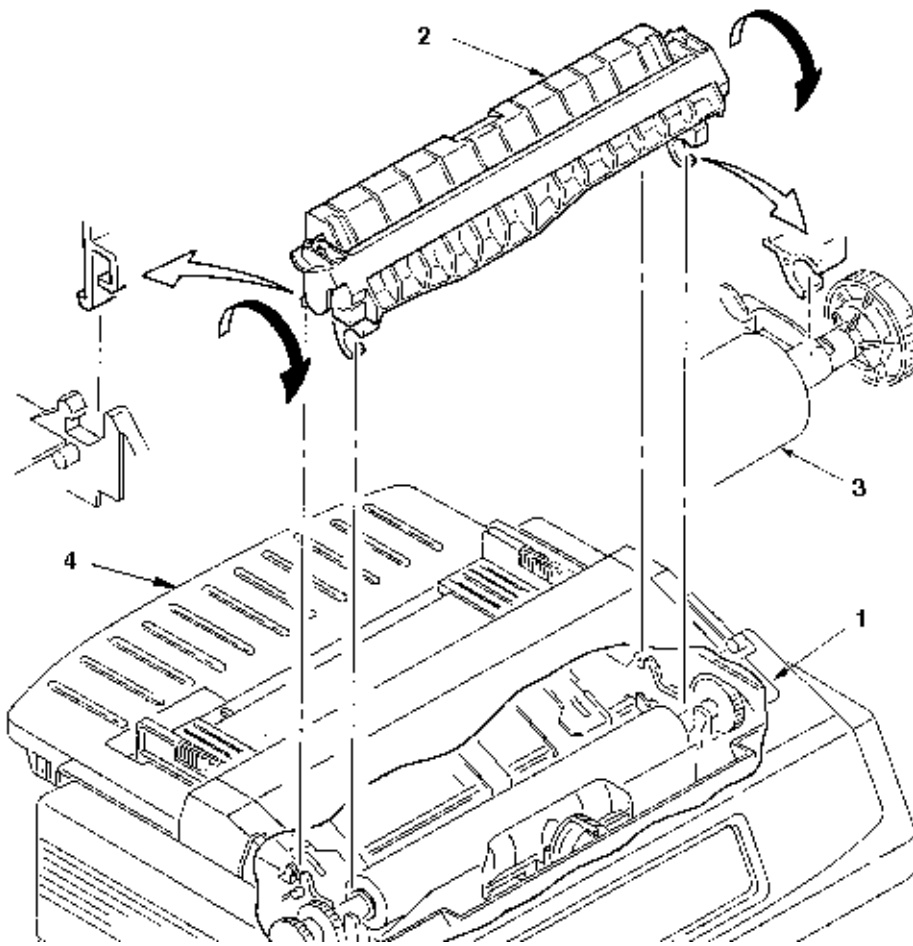

3.3.04 Upper Cover Assy, Access Cover Assy and Sheet Guide Assy

- (1) Pull off the platen knob 1.
- (2) Open the access cover Assy 4 toward the front to remove.
- (3) Lift up the sheet guide Assy 5 to remove.
- (4) Turn the change lever 2 toward the bottom position.
- (5) Insert a flat-blade screwdriver into grooves (5 places) (4 places for narrow type) of frame and twist to disengage claws of upper cover 3.
- (6) Raise the front side of upper cover Assy 3 and shift toward the rear to disengage claws (6 places) (5 places for narrow type) of frame.
- (7) Raise the upper cover Assy 3 to remove.
- (8) To install, follow the removal steps in the reverse order.

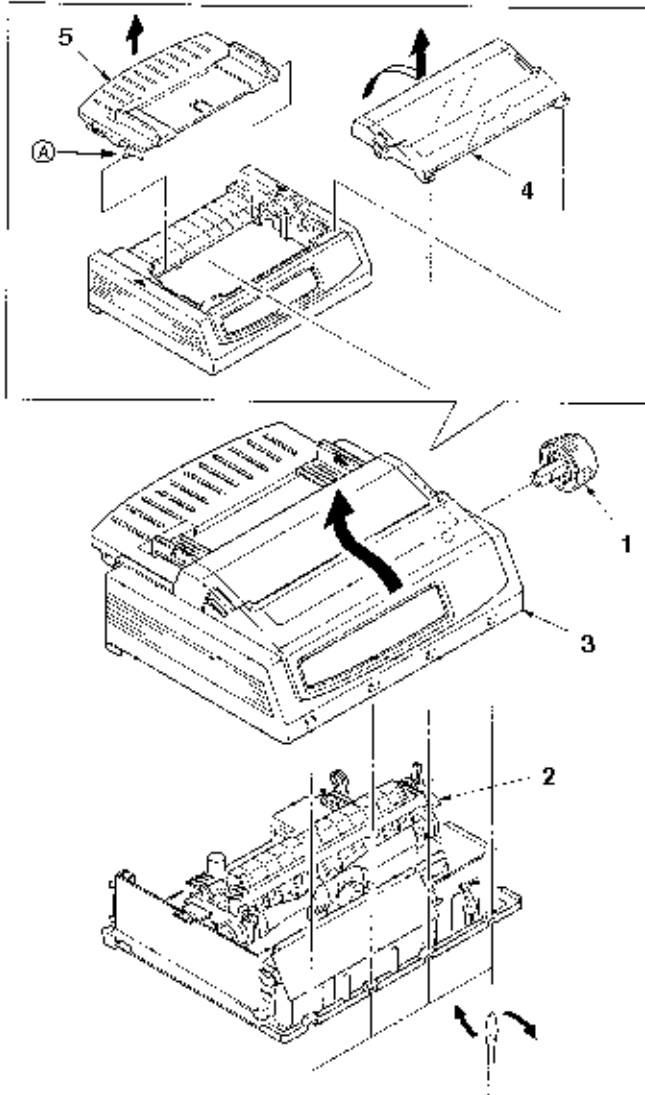

Remark on assembly:

Match the posts A at the both sides of the Sheet Guide 5 with the arrow marks on the upper cover. Push the Guide into the Cover.



Copyright 1997, Okidata, Division of OKI America, Inc. All rights reserved. See the OKIDATA Business Partner Exchange (BPX) for any updates to this material. (<http://bpx.okidata.com>)

3.3.05 Gear Case Assy

- (1) Remove the printhead ([see 3.3.1](#)).
- (2) Remove the upper cover ([see 3.3.4](#)).
- (3) Move the carriage Assy to right hand side, remove two screws 1, and then remove the space motor 2.
- (4) Disconnect a carriage cable.
- (5) Disengage claws (4 places).

Using a flat-blade screwdriver, push to widen the claw for easy disengagement.

- (6) Remove the gear case Assy 3 in upper direction and release the carriage cable from the cable clamp of the gear case A
- (7) To install, follow the removal steps in the reverse order.

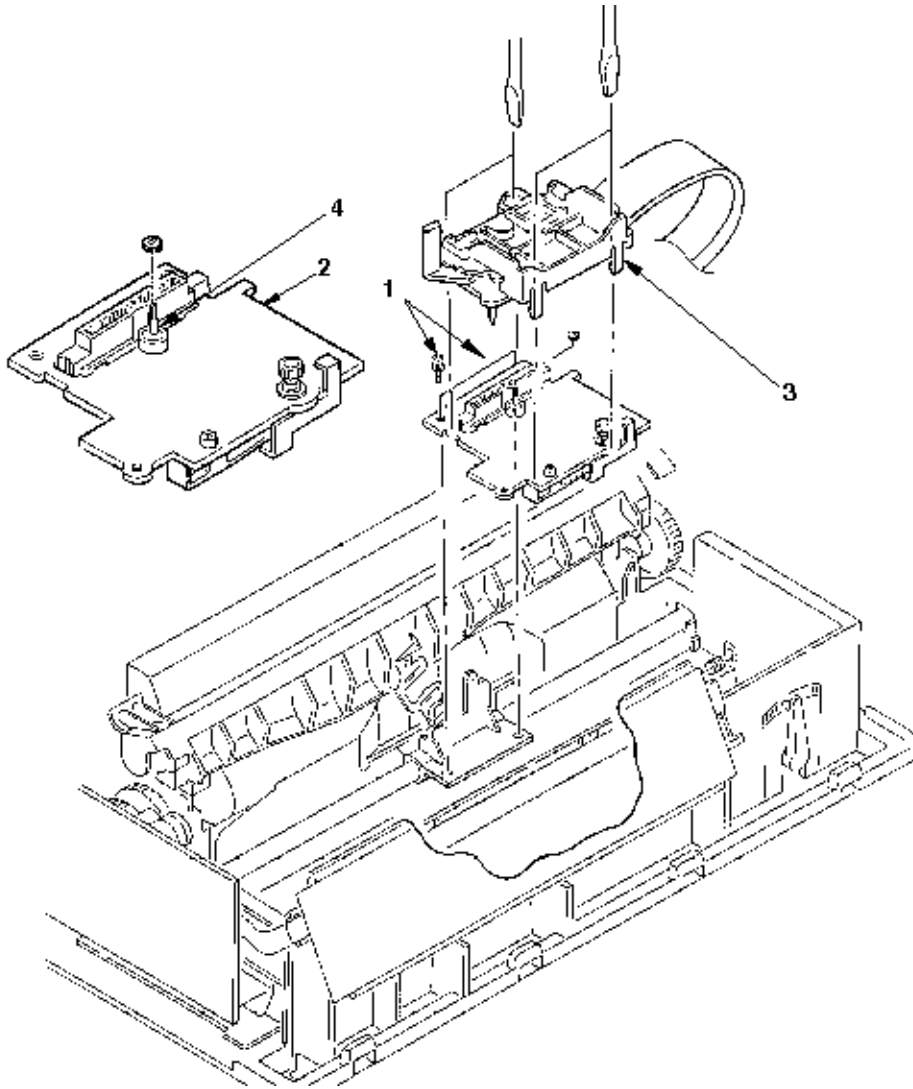

Note on installation:

- (1) To assemble, align the direction of the SP motor axis 4 with the Gear Hole of the Gear Case assy.
- (2) Be sure to check, and adjust if necessary, the gap between platen and printhead ([see 4-1](#)).



Copyright 1997, Okidata, Division of OKI America, Inc. All rights reserved. See the OKIDATA Business Partner Exchange (BPX) for any updates to this material. (<http://bpx.okidata.com>)

3.3.06 PC Connector

- (1) Remove the printhead ([see 3.3.1](#)).
- (2) Remove the upper cover ([see 3.3.4](#)).
- (3) Remove the gear case Assy ([see 3.3.5](#)).
- (4) Remove the PC connector 1 from the space motor Assy 2.
- (5) To install, follow the removal steps in the reverse order.



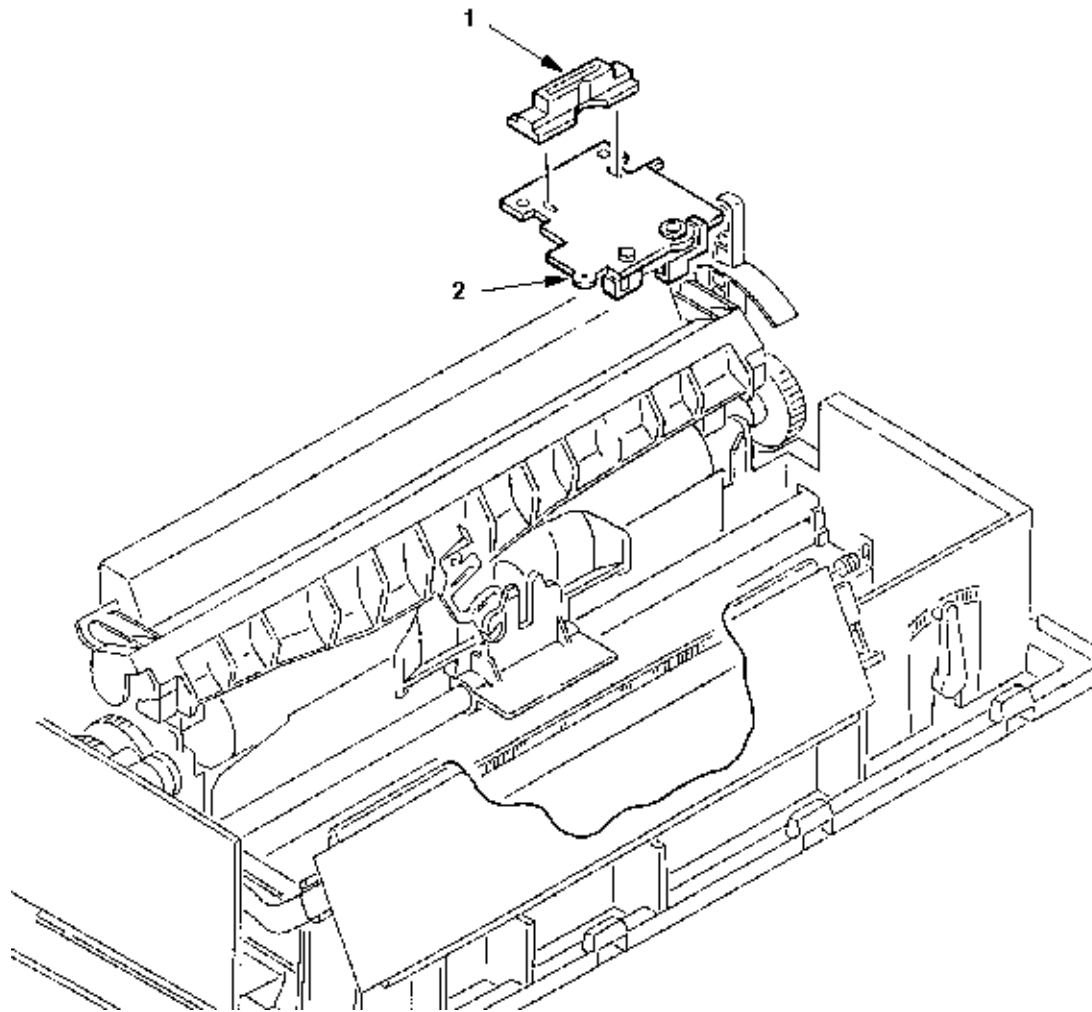

Note on installation:

- (1) Do not touch the space motor 2 or terminals of PC connector 1. Also, take care to avoid dust or foreign matters.
- (2) After installation, check and adjust the gap between platen and printhead ([see 4-1](#)).



Copyright 1997, Okidata, Division of OKI America, Inc. All rights reserved. See the OKIDATA Business Partner Exchange (BPX) for any updates to this material. (<http://bpx.okidata.com>)

3.3.07 Space Motor, Guide Roller Assy

- (1) Remove the printhead ([see 3.3.1](#)).
- (2) Remove the upper cover ([see 3.3.4](#)).
- (3) Remove the gear case Assy ([see 3.3.5](#)).
- (4) Remove the PC connector ([see 3.3.6](#)).
- (5) Remove screw 2, then the guide roller Assy 3 from the space motor 1.
- (6) Push down on the carriage cable and remove it.
- (7) Remove the screws (5), then remove the guide roller assembly (3) from the space motor assembly.
- (8) Remove the space motor
- (9) To install, follow the removal steps in the reverse order.



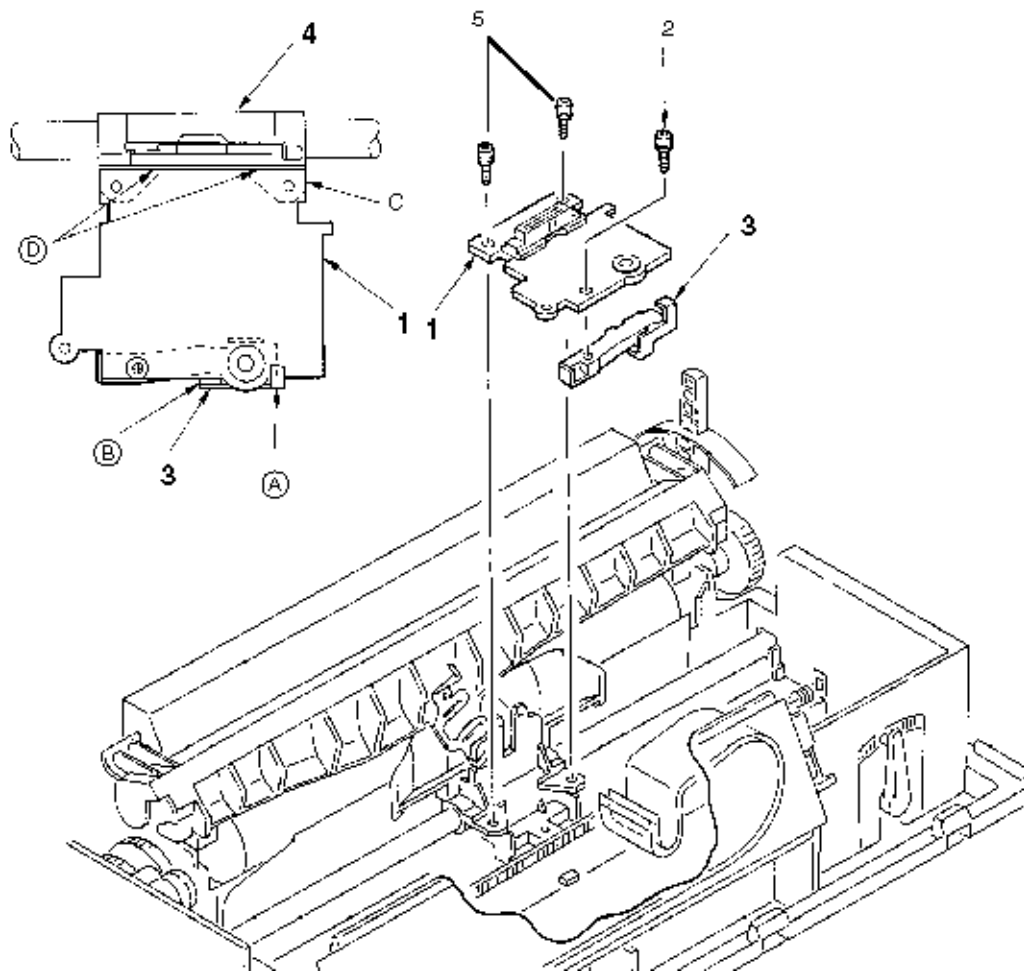

Notes on installation:

- (1) Do not touch the terminals of space motor 1. Also, take care to avoid dust or foreign matters.
- (2) When installing the guide roller Assy 3, push portions A and B against the space motor 1.
- (3) When installing the space motor 1, align the face C with carriage frame 4 and push portion D against the frame.
- (4) After installation, check and adjust the gap between platen and printhead ([see 4-1](#)).



Copyright 1997, Okidata, Division of OKI America, Inc. All rights reserved. See the OKIDATA Business Partner Exchange (BPX) for any updates to this material. (<http://bpx.okidata.com>)

3.3.08 Space Rack

- (1) Remove the printhead ([see 3.3.1](#)).
- (2) Remove the upper cover ([see 3.3.4](#)).
- (3) Remove the shim from the carriage frame.
- (4) Remove the gear case Assy ([see 3.3.5](#)).
- (5) Remove the space motor ([see 3.3.7](#)).
- (6) Remove the spring 1.
- (7) Disengage the claw on left side of space rack 2 from the frame, and remove the space rack 2 in upper direction.
- (8) To install, follow the removal steps in the reverse order.



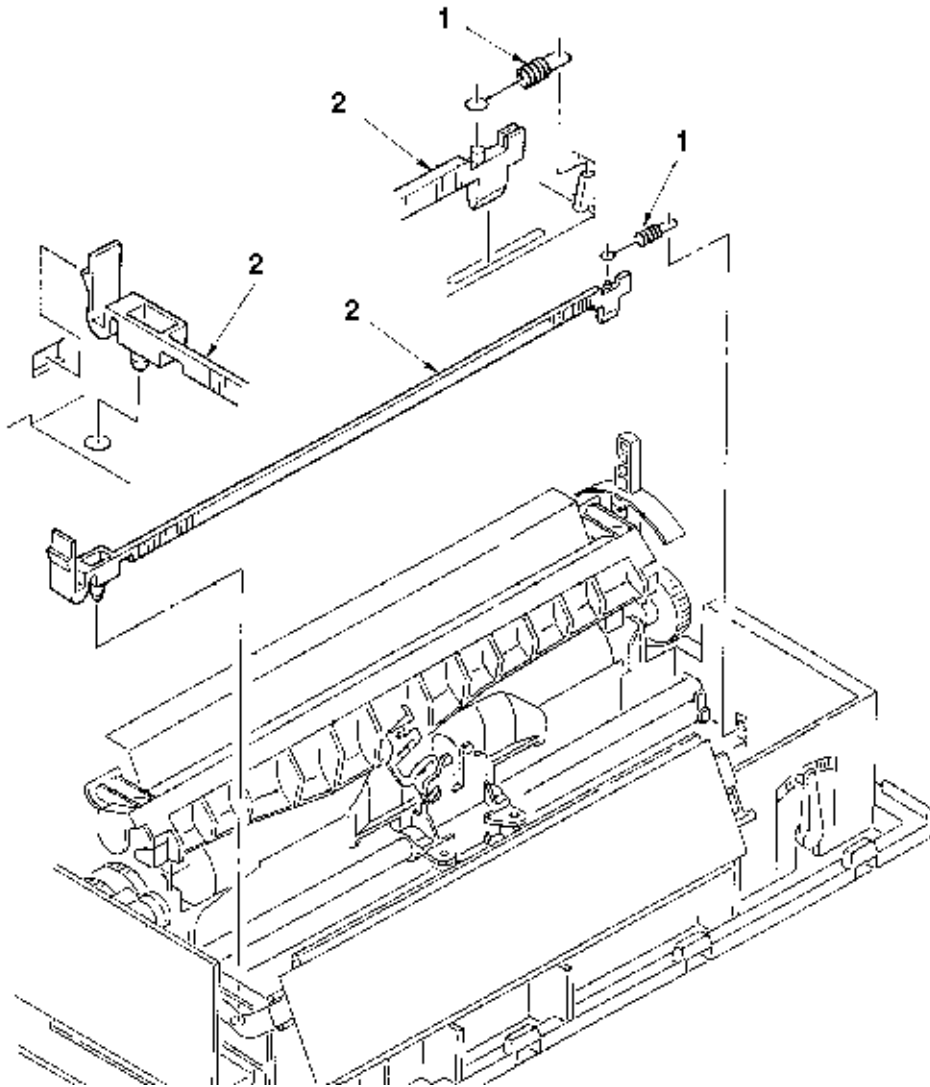

Note on installation:

- (1) After installation, check and adjust the gap between platen and printhead ([see 4-1](#)).



Copyright 1997, Okidata, Division of OKI America, Inc. All rights reserved. See the OKIDATA Business Partner Exchange (BPX) for any updates to this material. (<http://bpx.okidata.com>)

3.3.09 Carriage Cable

- (1) Remove the printhead ([see 3.3.1](#)).
- (2) Remove the upper cover ([see 3.3.4](#)).
- (3) Remove the gear case Assy ([see 3.3.5](#)).
- (4) Remove the space motor ([see 3.3.7](#)).
- (5) Remove the space rack ([3.3.8](#)).
- (6) Remove two screws 1, release the driver board 2 and PCB sheet 9 by lifting clamp 8, and disconnect cable from connector 3, 4, 5, 6.
- (7) Remove carriage cable 7 from fasteners on frame.
- (8) To install, follow the removal steps in the reverse order.

Note on installation:

- (1) Take care not to fold the carriage cable 7 during installation. Curve slightly the carriage cable 7 when assembling into the fasteners.
- (2) Make sure that the paper end lever A will not contact the Paper end Sensor 0 when mounting the Driver Board.

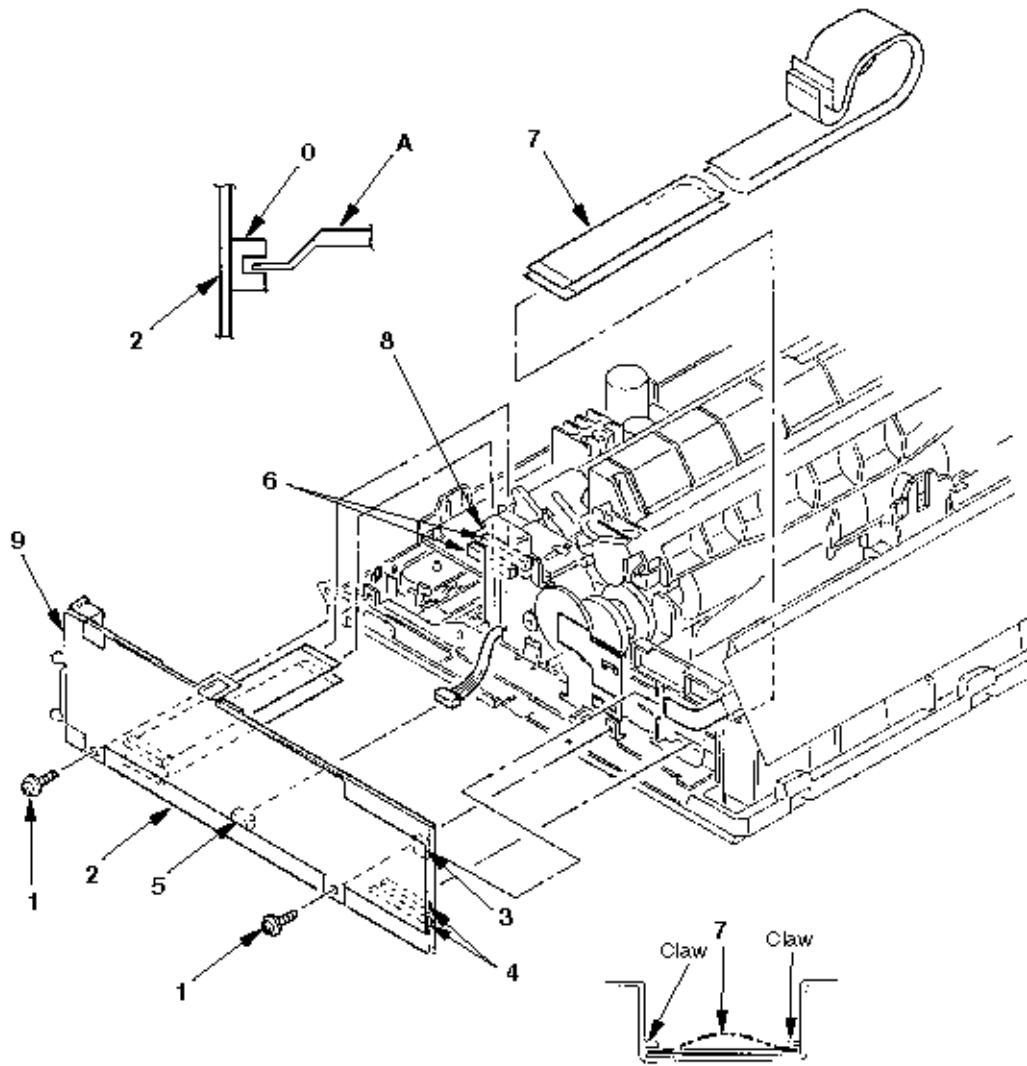

Copyright 1997, Okidata, Division of OKI America, Inc. All rights reserved. See the OKIDATA Business Partner Exchange (BPX) for any updates to this material. (<http://bpx.okidata.com>)

3.3.10 Backup Roller Holder Assy

- (1) Remove the printhead (see 3.3.1).
- (2) Remove the upper cover (see 3.3.4).
- (3) Remove the gear case Assy (see 3.3.5).
- (4) Remove the backup roller spring 2.



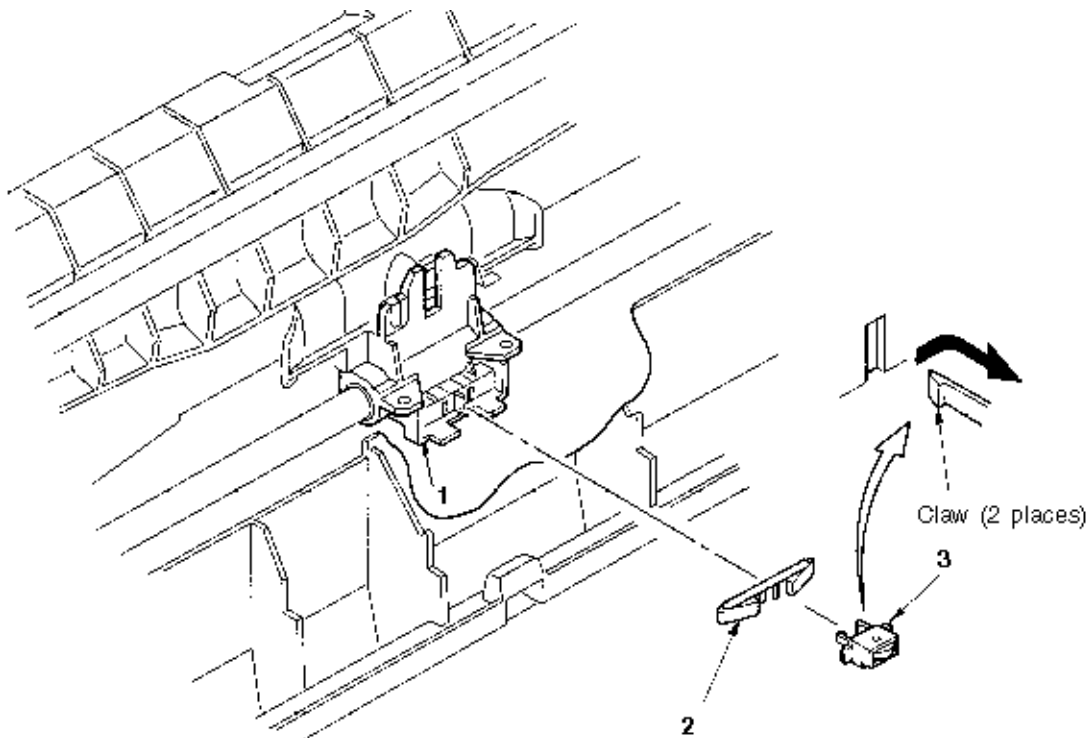

Disengage claws (2 places) of roller holder from the carriage frame 1, and remove the backup roller holder assy 3.

- (5) To install, follow the removal steps in the reverse order.



Note: Small round hole with metal tip on back up roller holder assy 3 should be facing up when installing.

3.3.11 Platen Assy

- (1) Remove the printhead ([see 3.3.1](#)).
- (2) Remove the ribbon protector ([see 3.3.2](#)).
- (3) Remove the pull-up roller Assy ([see 3.3.3](#)).
- (4) Remove the upper cover ([see 3.3.4](#)).
- (5) Turn the change lever 1 to the bottom position.
- (6) Push in the lock levers 2 on both sides to unlock from the frame, then rotate them upward by 90°.
- (7) Remove the platen Assy 4 from base frame.
- (8) To install, follow the removal steps in the reverse order.

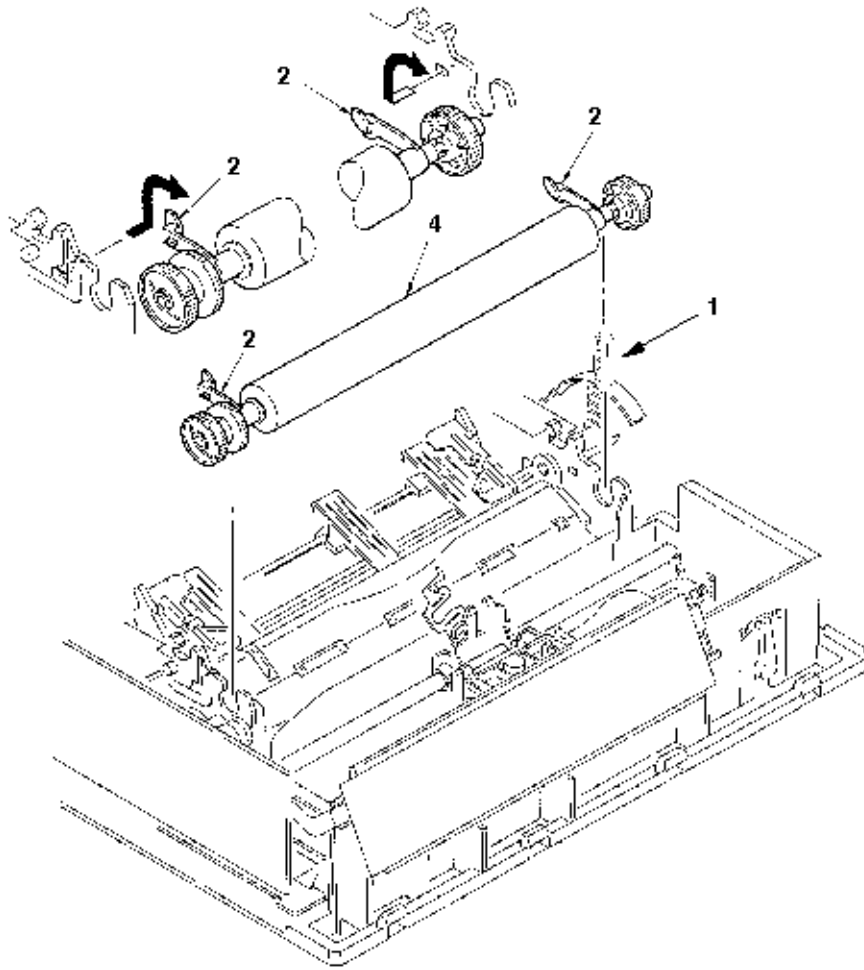

Copyright 1997, Okidata, Division of OKI America, Inc. All rights reserved. See the OKIDATA Business Partner Exchange (BPX) for any updates to this material. (<http://bpx.okidata.com>)

3.3.12 Driver Board (SRXD)

- (1) Remove the upper cover ([see 3.3.4](#)). 
- (2) Remove two screws 1, lift clamp 4, and release the driver board 2 and PCB sheet 5.
- (3) Disconnect all cables from driver board 2.
- (4) To install, follow the removal steps in the reverse order.





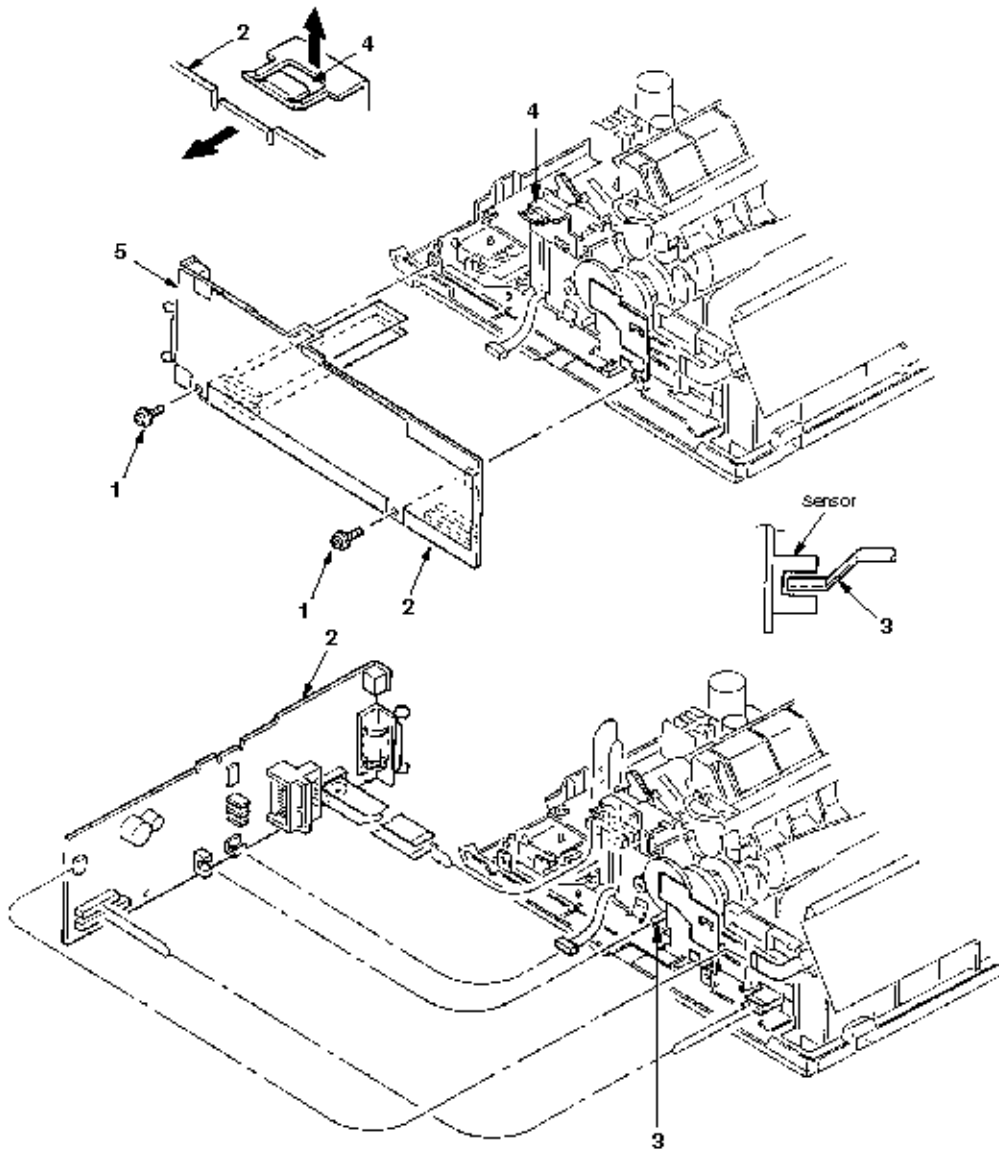

Note on installation:

- (1) Insert one sensor lever 3 between sensor when installing the driver board 2.



Copyright 1997, Okidata, Division of OKI America, Inc. All rights reserved. See the OKIDATA Business Partner Exchange (BPX) for any updates to this material. (<http://bpx.okidata.com>)

3.3.13 LF Motor

- (1) Remove the printhead [\(see 3.3.1\)](#). 
- (2) Remove the ribbon protector [\(see 3.3.2\)](#). 
- (3) Remove the pull-up roller Assy [\(see 3.3.3\)](#). 
- (4) Remove the upper cover [\(see 3.3.4\)](#). 
- (5) Remove the platen Assy [\(see 3.3.11\)](#). 
- (6) Remove the driver board [\(see 3.3.12\)](#). 
- (7) Remove the left FG plate 1.
- (8) Release the lock A to remove the LF motor 2.
- (9) To install, follow the removal steps in the reverse order.

Remark on assembly:

- (1) Press the LF Motor Cable with a portion A of the Motor Plate.

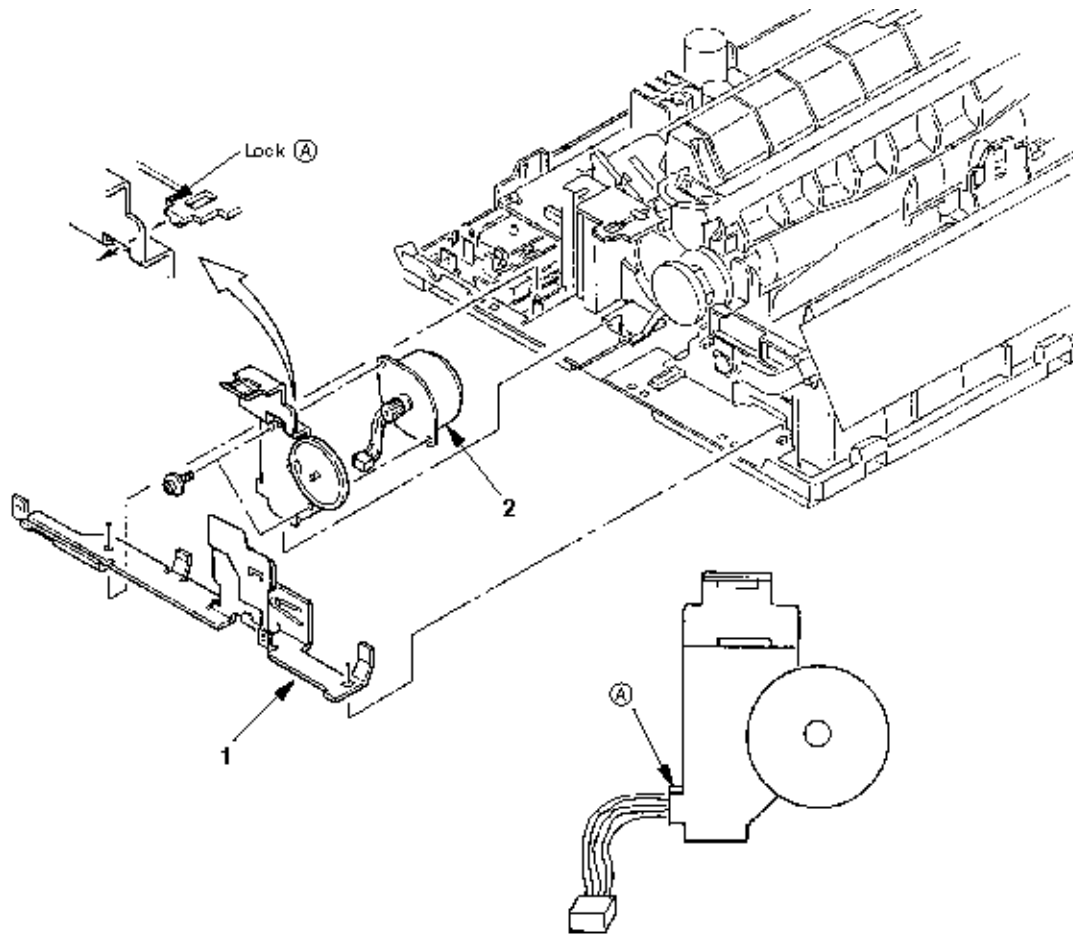

Copyright 1997, Okidata, Division of OKI America, Inc. All rights reserved. See the OKIDATA Business Partner Exchange (BPX) for any updates to this material. (<http://bpx.okidata.com>)

3.3.14 Operation Panel PCB (LEOP)

- (1) Remove the upper cover (see 3.3.4).
- (2) Disconnect the cable 1 from connector 3 of Driver board 2.
- (3) Disengage claws on both sides from the frame, and remove the operation panel 4.
- (4) Open claws (8 places) and remove the operation panel PCB 5 from the operation panel 4.
- (5) To install, follow the removal steps in the reverse order.

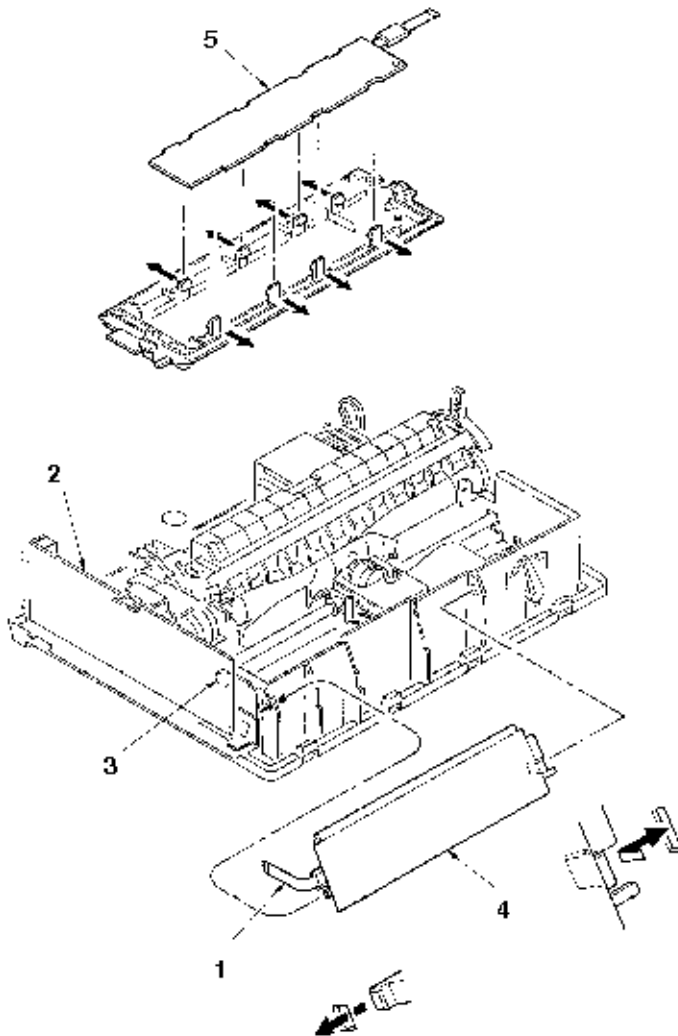

Copyright 1997, Okidata, Division of OKI America, Inc. All rights reserved. See the OKIDATA Business Partner Exchange (BPX) for any updates to this material. (<http://bpx.okidata.com>)

3.3.15 Control/Power Supply Board (SRXC)

- (1) Remove the upper cover ([see 3.3.4](#)). 
- (2) Disconnect two flexible cable 3 from the connector 2 the Control/Power Supply Board 1.
- (3) Remove the cable 5 from the connector 4 on the Control/Power Supply board 1.
- (4) Remove two screws 6, and remove the Control/Power Supply Board 1.
- (5) To install, follow the removal steps in the reverse order.

Remark on assembly:

- (1) To mount the Control/Power Supply Board, set the change lever to the top position so that the Switch Lever 7 will not hooked on the microswitches 8.

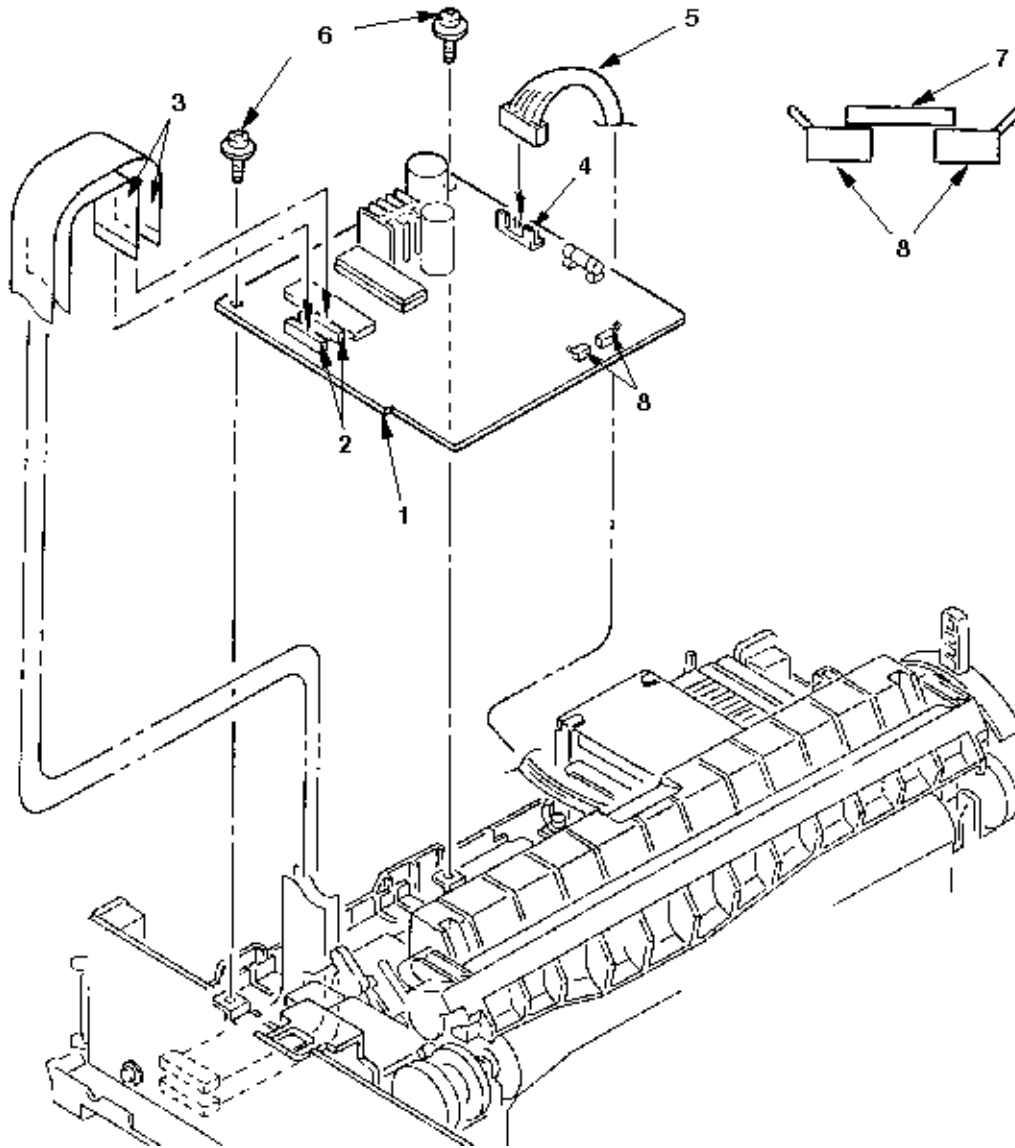

Copyright 1997, Okidata, Division of OKI America, Inc. All rights reserved. See the OKIDATA Business Partner Exchange (BPX) for any updates to this material. (<http://bpx.okidata.com>)

3.3.16 Transformer Assy

- (1) Remove the upper cover (see 3.3.4).
- (2) Remove AC inlet 1 and AC switch 2 from the frame guide.
- (3) Disconnect the cable 3 from the connector 4 on the Control/Power Supply Board 5.
- (4) Remove a screw 6 and disconnect ground cable 7.
- (5) Remove two screws 8 and shift the transformer Assy 9 to the left and remove it.

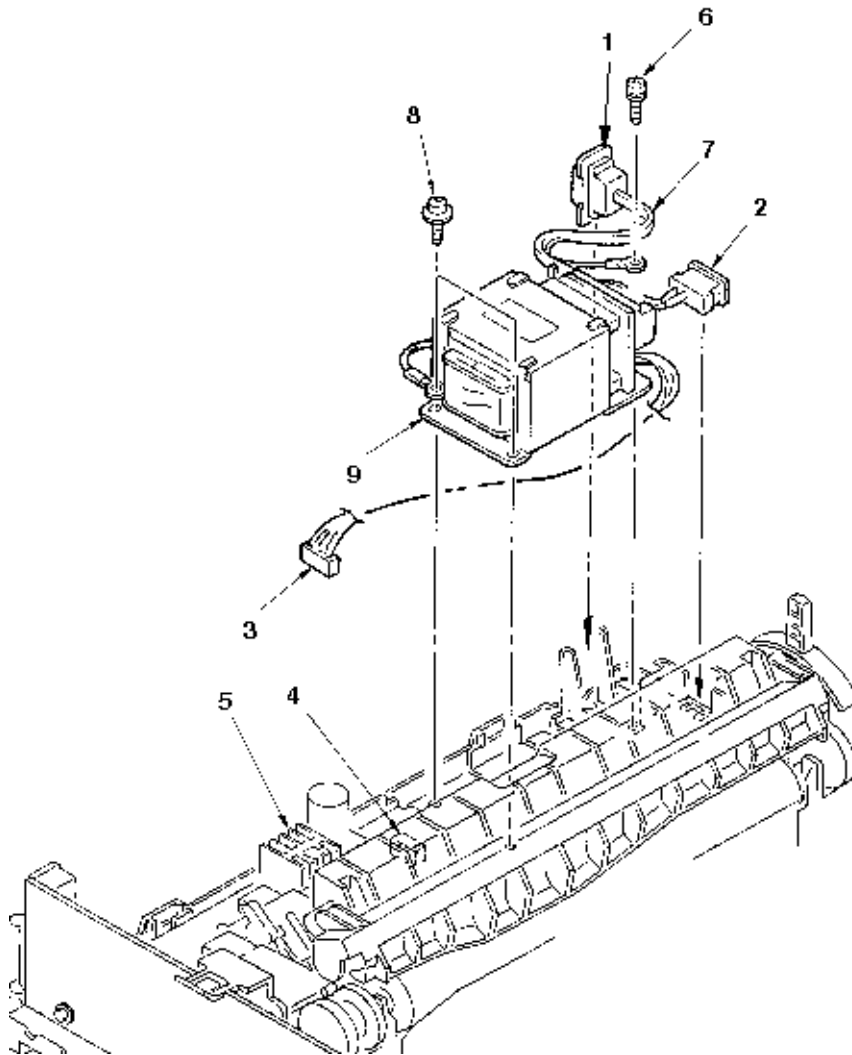

Copyright 1997, Okidata, Division of OKI America, Inc. All rights reserved. See the OKIDATA Business Partner Exchange (BPX) for any updates to this material. (<http://bpx.okidata.com>)

3.3.17 Change Lever and Gears

- (1) Remove the upper cover ([see 3.3.4](#)). 
- (2) Remove the reset spring 1, then remove the idle gear 2, the tractor gear 4 and the change gear 5.
- (3) Push back the protrusion of the Change Gear Shaft 6 with a flatblade screw driver to remove the change lever 3.
- (4) To perform mounting, follow the reverse procedure of removal.

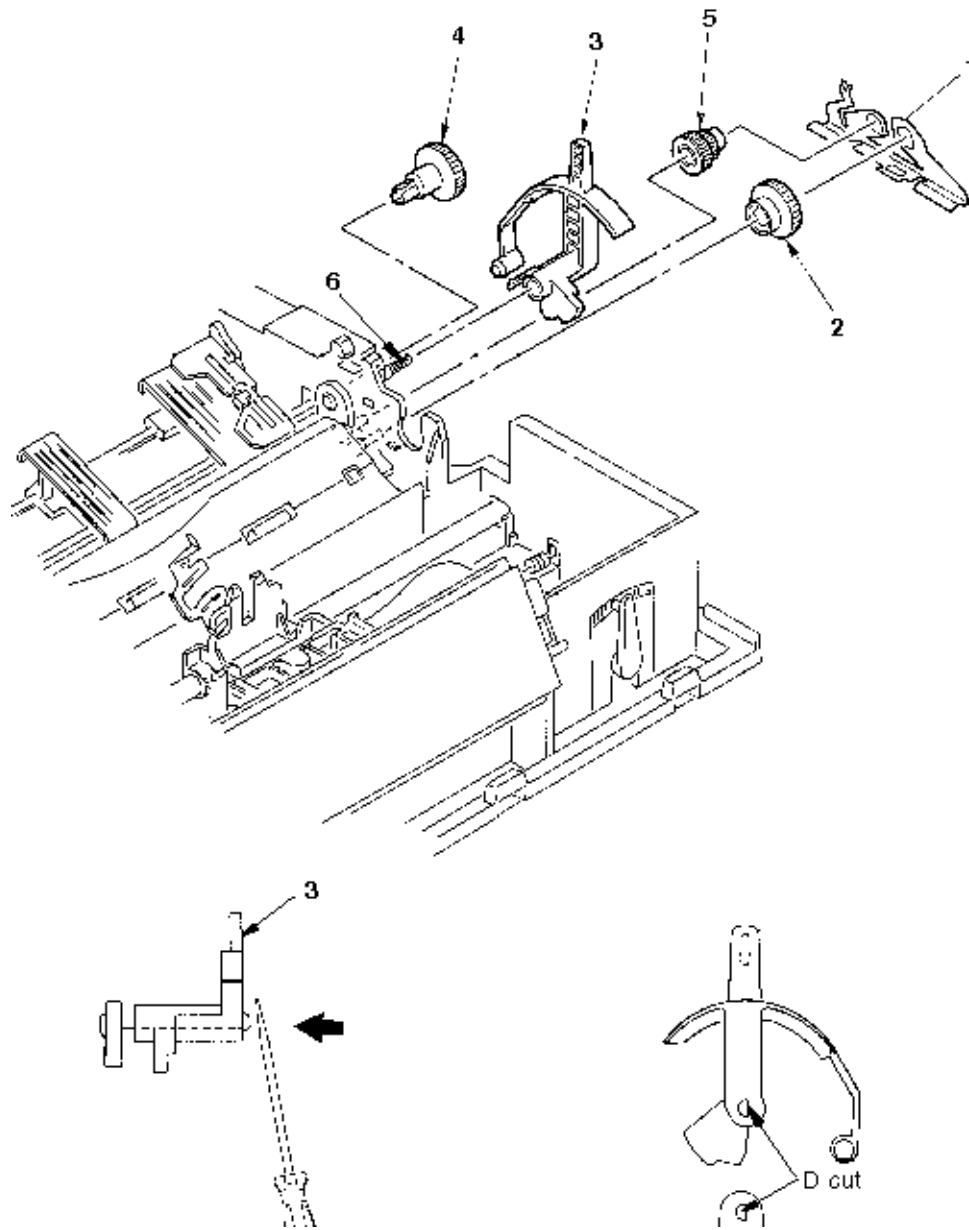

Remark on assembly:

- (1) To insert the change lever into the Change Gear Shaft 6, match the flat surface (D cut).



Copyright 1997, Okidata, Division of OKI America, Inc. All rights reserved. See the OKIDATA Business Partner Exchange (BPX) for any updates to this material. (<http://bpx.okidata.com>)

3.3.18 Carriage Shaft

- (1) Remove the printhead ([see 3.3.1](#)). 
- (2) Remove the upper cover ([see 3.3.4](#)). 
- (3) Remove the driver board ([see 3.3.12](#)). 
Remove the FG plate (L) 2.
- (4) Slide the carriage shaft 1 to the left side (in the direction of the arrow) to remove.
- (5) To perform mounting, follow the reverse procedure of removal.

Note on installation:

- (1) After installation, check and adjust the gap between platen and printhead ([see 4-1](#)). 

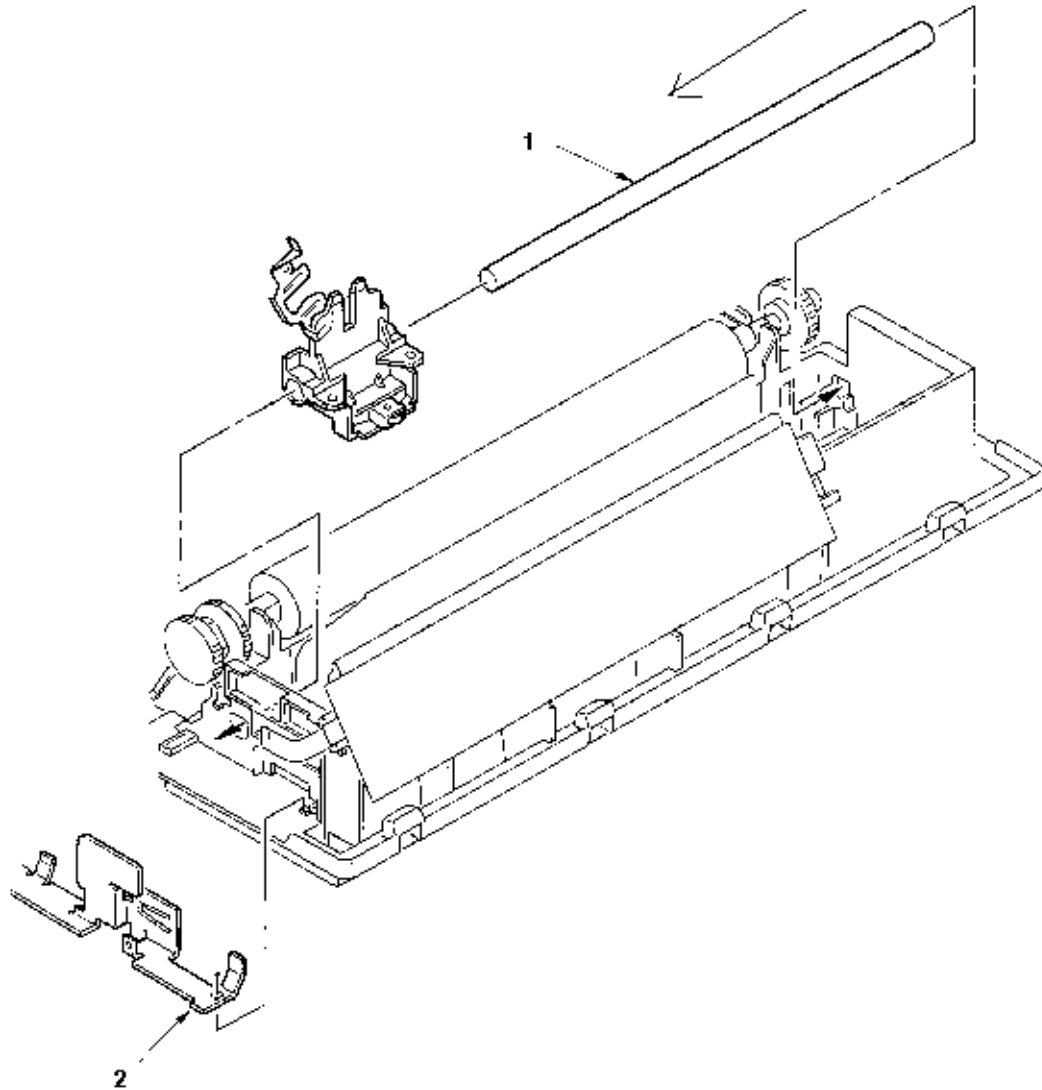

Copyright 1997, Okidata, Division of OKI America, Inc. All rights reserved. See the OKIDATA Business Partner Exchange (BPX) for any updates to this material. (<http://bpx.okidata.com>)



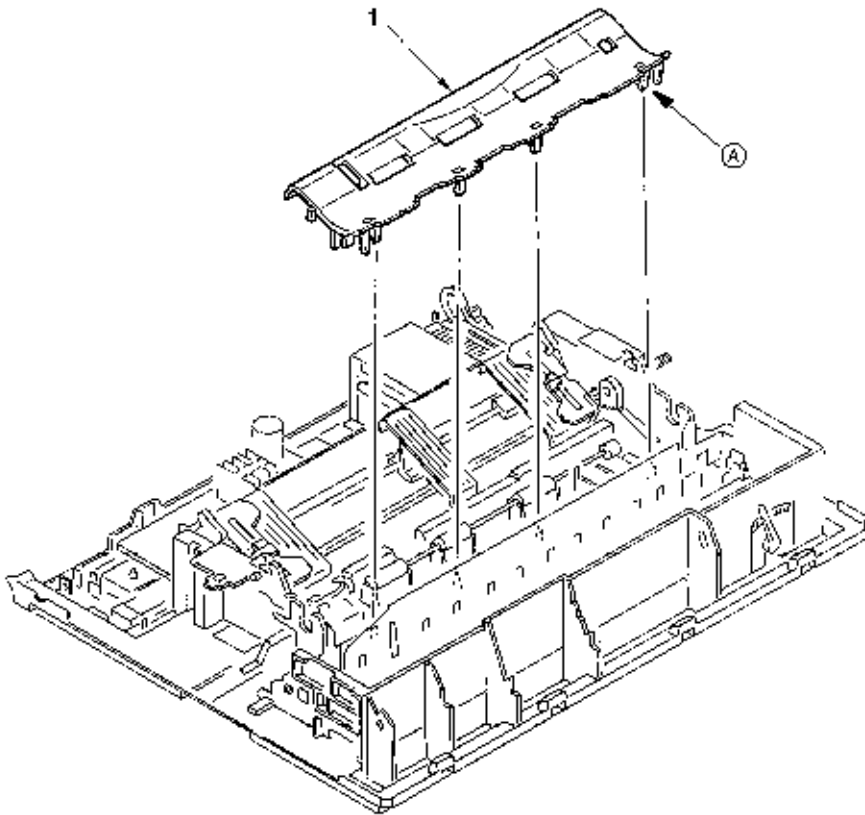

3.3.19 Paper Pan

- (1) Remove the printhead (see 3.3.1).
- (2) Remove the ribbon protector (see 3.3.2).
- (3) Remove the pull-up roller assy (see 3.3.3).
- (4) Remove the upper cover assy (see 3.3.4).
- (5) Remove the platen assy (see 3.3.11).
- (6) Release claws A .
- (7) Lift up the paper chute assy 1 and remove.
- (8) To perform mounting, follow the reverse procedure of removal.



Copyright 1997, Okidata, Division of OKI America, Inc. All rights reserved. See the OKIDATA Business Partner Exchange (BPX) for any updates to this material. (<http://bpx.okidata.com>)

3.3.20 Rear Tractor Assy

- (1) Remove the printhead [\(see 3.3.1\)](#). 
- (2) Remove the ribbon protector [\(see 3.3.2\)](#). 
- (3) Remove the pull-up roller assy [\(see 3.3.3\)](#). 
- (4) Remove the upper cover [\(see 3.3.4\)](#). 
- (5) Remove the reset spring [\(see 3.3.17\)](#). 
- (6) Remove the tractor gear 1.
- (7) Shift the drive shaft 2 to the right side to remove (in the direction of the arrow).
- (8) To perform mounting, follow the reverse procedure of removal.

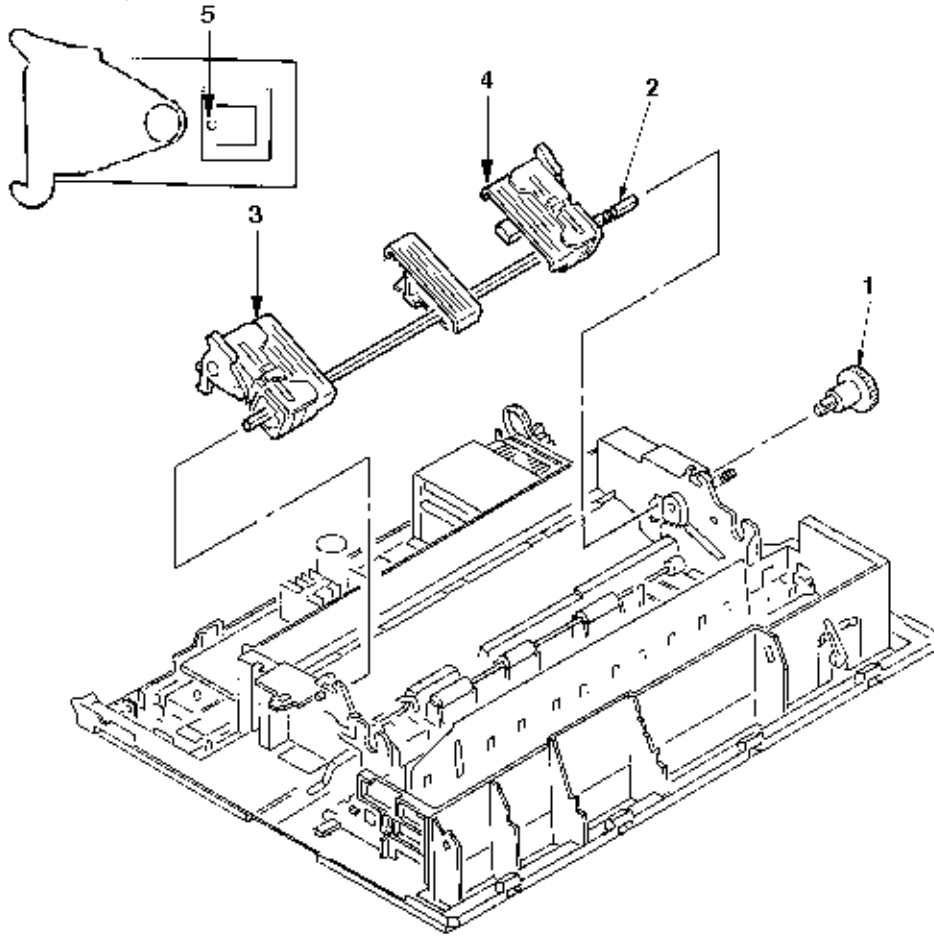

Remark on assembly:

- (1) When the Tractor Assy (L) 3 (R) 4 have been detached from the Drive Shaft, align the protrusions 5 of the Pin Tractor Wheels to the same direction before assembly.



Copyright 1997, Okidata, Division of OKI America, Inc. All rights reserved. See the OKIDATA Business Partner Exchange (BPX) for any updates to this material. (<http://bpx.okidata.com>)

3.3.21 Rear Pressure Assy

- (1) Remove the upper cover (see 3.3.4). 
- (2) Remove the change lever and gears (see 3.3.17). 
- (3) Remove the paper pan (see 3.3.19). 
- (4) Remove the rear pressure roller 1.
- (5) Rotate the release shaft 2 and move it to the left to detach the release shaft 2. Match the Main Frame Rib A with the protrusion B of the Release Shaft.
- (6) Remove rear pressure SP assy 3.
- (7) To install, follow the removal step in the reverse order.



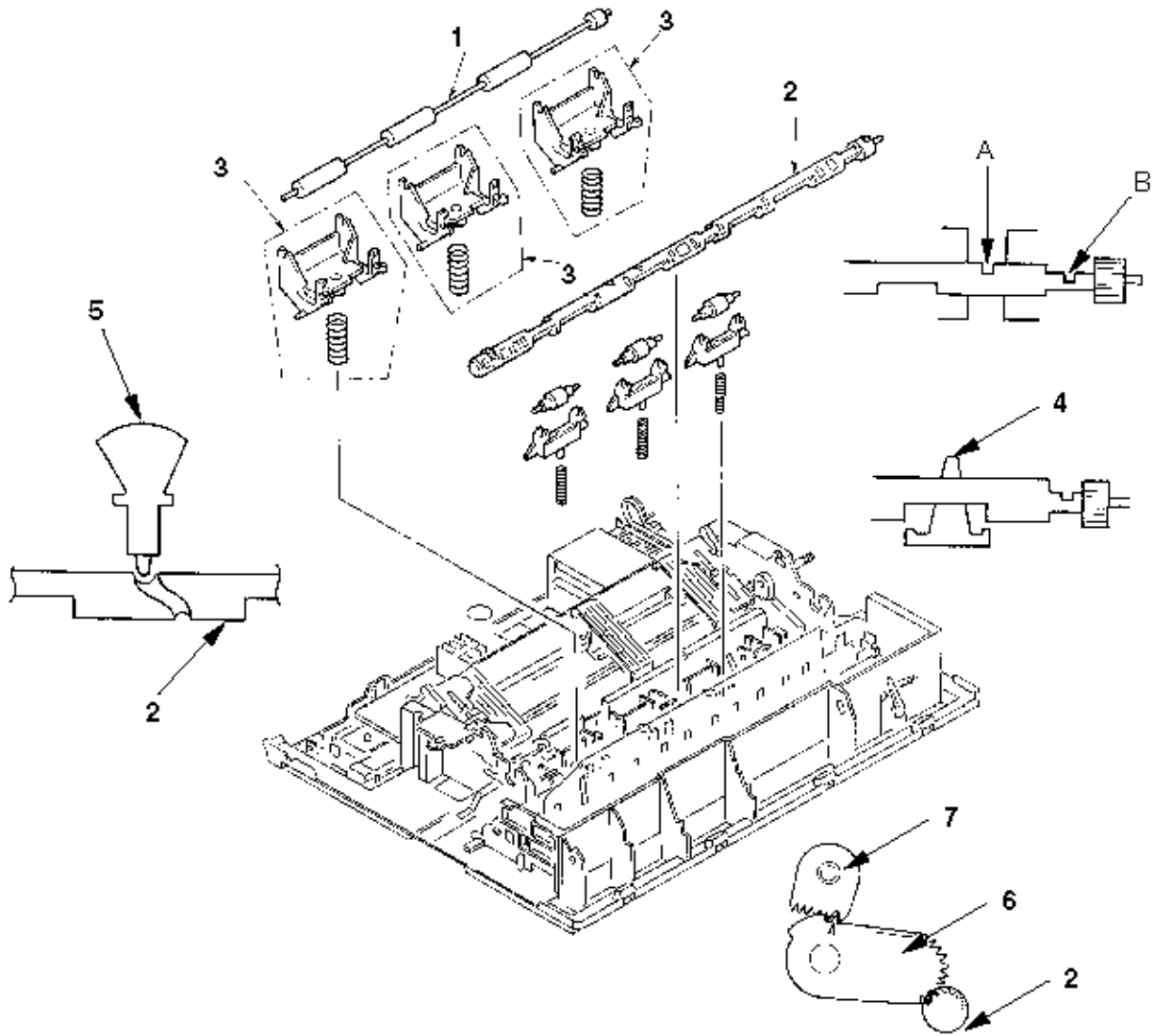

Note:

- (1) At mounting release shaft 2, pay attention to the gear engagement of release shaft 2, change arm lever 6, change gear shaft 7.
- (2) There are 5 Rear pressure Spring Assemblies. Use two pieces which have larger spring diameter on the right side. Use three remaining pieces on the left side (for ML391 Turbo).
- (3) Make sure that the Release Shaft 2 will be on top of the Support spring 4.
- (4) To assemble the Release Shaft 2, make sure that the protrusion of the switch lever 5 is in the U groove of the Release Shaft 2.



Copyright 1997, Okidata, Division of OKI America, Inc. All rights reserved. See the OKIDATA Business Partner Exchange (BPX) for any updates to this material. (<http://bpx.okidata.com>)

3.3.22 Switch Lever

- (1) Remove the upper cover ([see 3.3.4](#)).
- (2) Remove the change lever and gears ([see 3.3.17](#)).
- (3) Remove the paper pan ([see 3.3.19](#)).
- (4) Remove the rear pressure assy ([see 3.3.21](#)).
- (5) Pull the Switch Lever toward you and remove it upward.
- (6) To install, follow the removal step in the reverse order.

Remark on assembly:

- (1) At the time of the Switch Lever assembly, make sure that the Micro switch on the Main Board works properly.

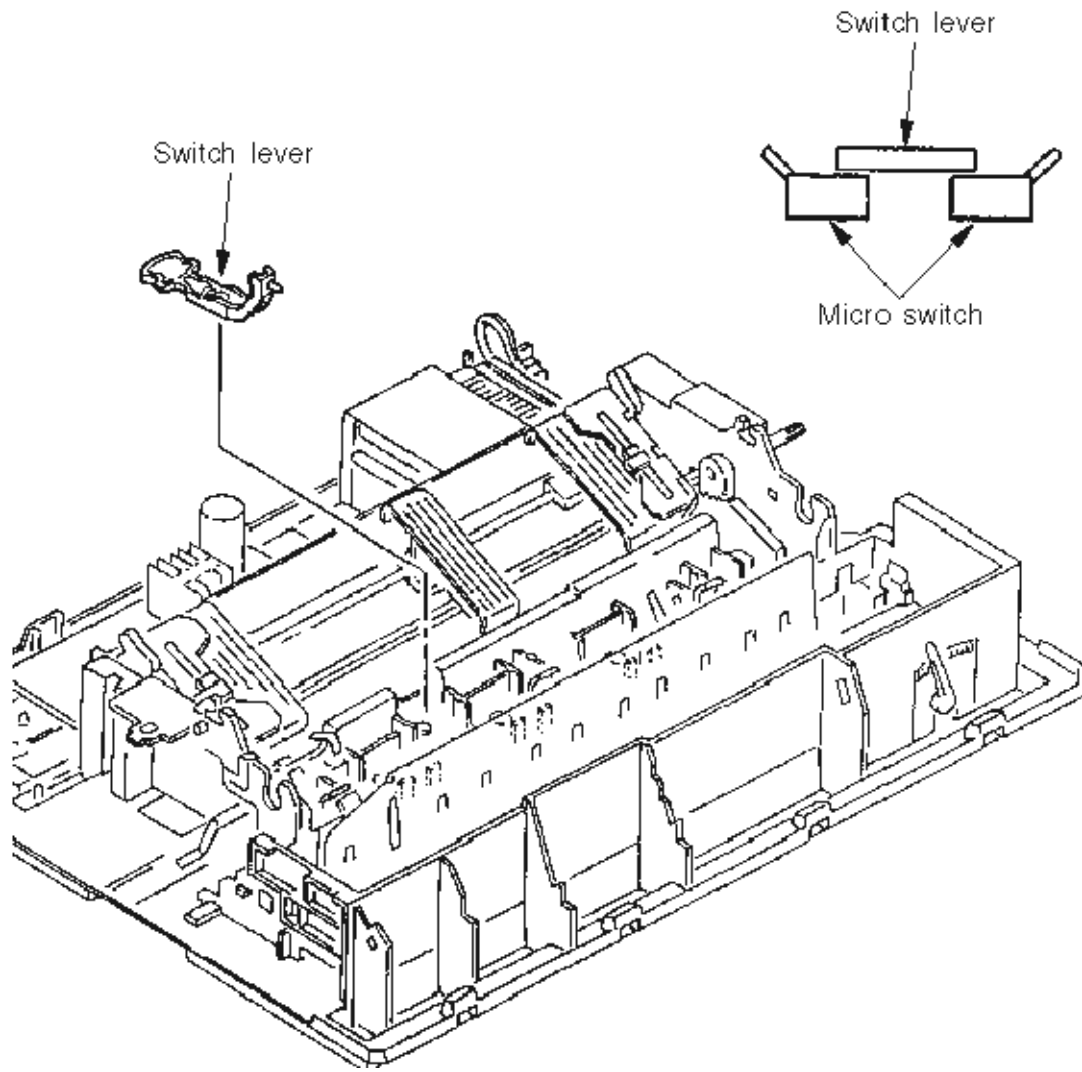

Copyright 1997, Okidata, Division of OKI America, Inc. All rights reserved. See the OKIDATA Business Partner Exchange (BPX) for any updates to this material. (<http://bpx.okidata.com>)

4. ADJUSTMENT

- (1) Be sure to carry out this adjustment with the printer mechanism mounted on the lower cover.
 - (2) Be sure to carry out this adjustment operation on a level and highly rigid work table (flatness: less than 0.039 inch or 1 mm) so as to minimize adjustment error.
-

Copyright 1997, Okidata, Division of OKI America, Inc. All rights reserved. See the OKIDATA Business Partner Exchange (BPX) for any updates to this material. (<http://bpx.okidata.com>)

4-1-1 Gap between the platen and the printhead

No.	Item	Specification	Drawing	Adjustment method
4-1-1	Gap between the platen and the printhead			It shall be measured at 3 points, the left end, the center and the right end of the platen.
	1) Parallelism adjustment	Variation of value at the left, the center and the right shall be less than 0.02 mm		Adjustment method (1) Gap between the platen and the printhead at the left end and the right end shall be adjusted by rotating the adjust cam. (2) Set the adjust lever at the Range: 1. Press the adjust gear downward (in direction A) to push the adjust gear and the adjust gear out of mesh.
	2) Initial adjustment	.041 0.03 mm		(3) Adjust the gap by rotating the adjust screw in direction B or C while the adjust lever and the adjust gear are disengaged. (4) After adjustment, mark the adjust cam position with a red pen.

After adjustment, mark the adjust composition with a red pen.

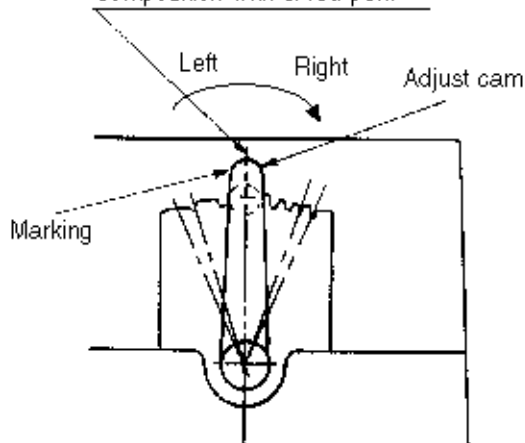

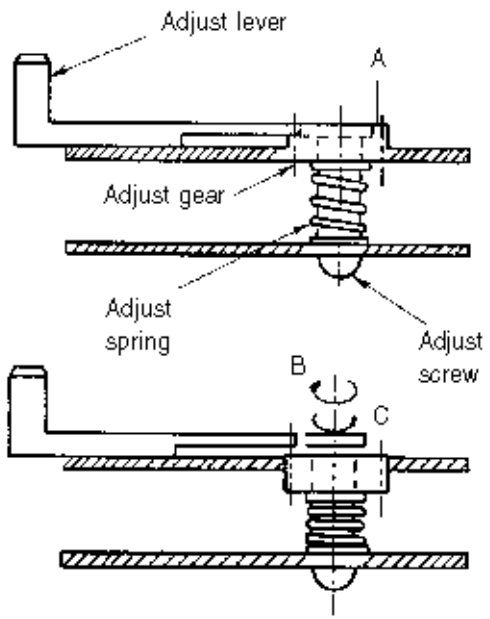
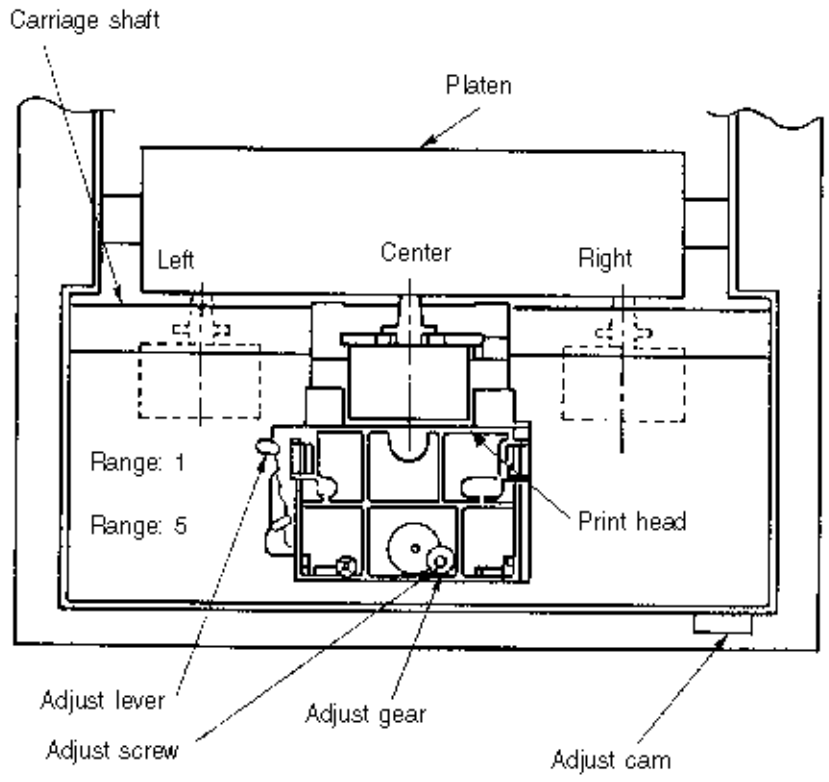

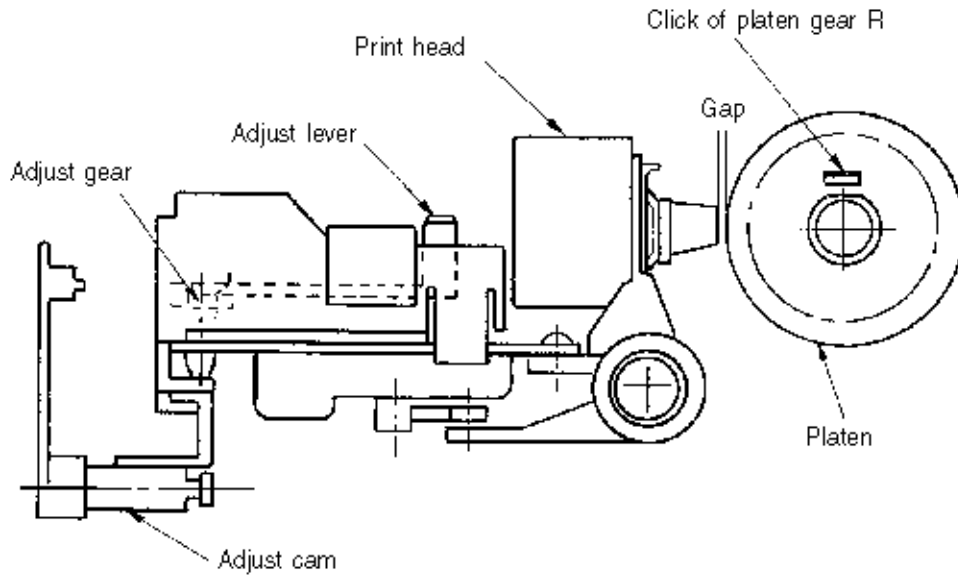

Copyright 1997, Okidata, Division of OKI America, Inc. All rights reserved. See the OKIDATA Business Partner Exchange (BPX) for any updates to this material. (<http://bpx.okidata.com>)

4-1-2 Measure variation of gap when range is changed.

No.	Item	Specification	Drawing	Adjustment method
4-1-2	Measure variation of gap when range is changed. Gap between the contact and the monitor	Gap = 0.71 0.05 at the range 5. .03mm or more		Confirm followings. Make sure that the gap between the contact and the motor PCB is 0.33 mm or more. At the time of printing test, make sure that the contact touches the motor PCB and it becomes reduced speed mode when the adjust lever is set to range 2 and 4.

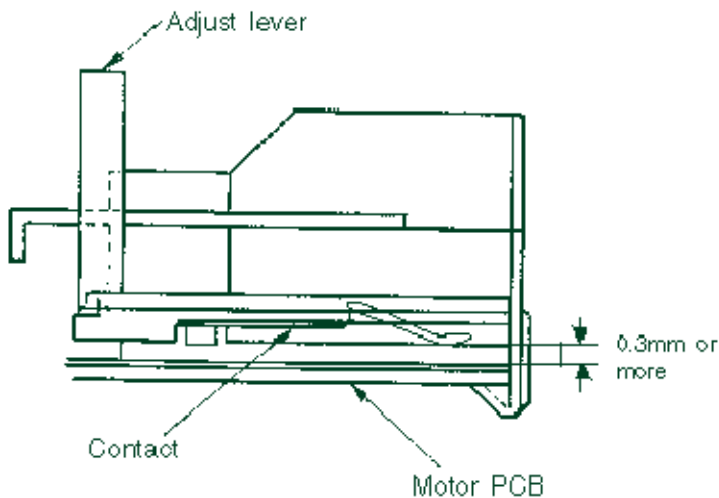

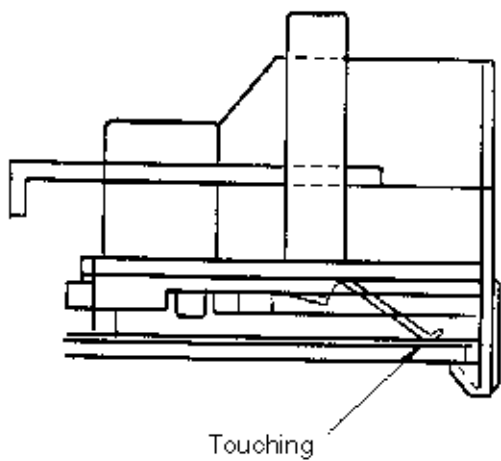

Copyright 1997, Okidata, Division of OKI America, Inc. All rights reserved. See the OKIDATA Business Partner Exchange (BPX) for any updates to this material. (<http://bpx.okidata.com>)

4-2 Gap between the platen and the paper pan

No.	Item	Specification	Drawing	Adjustment method
4-2	Gap between the platen and the paper pan.	1 0.5	see below	<p>Confirm followings.</p> <p>(1) When the change lever is set at Friction position, the gap between the platen and the paper pan at the rear side shall be 1 0.5mm.</p> <p>(2) When the change lever is set at Rear or Bottom position, the gap between the platen and the paper pan at the front side shall be 1 0.5 mm.</p>

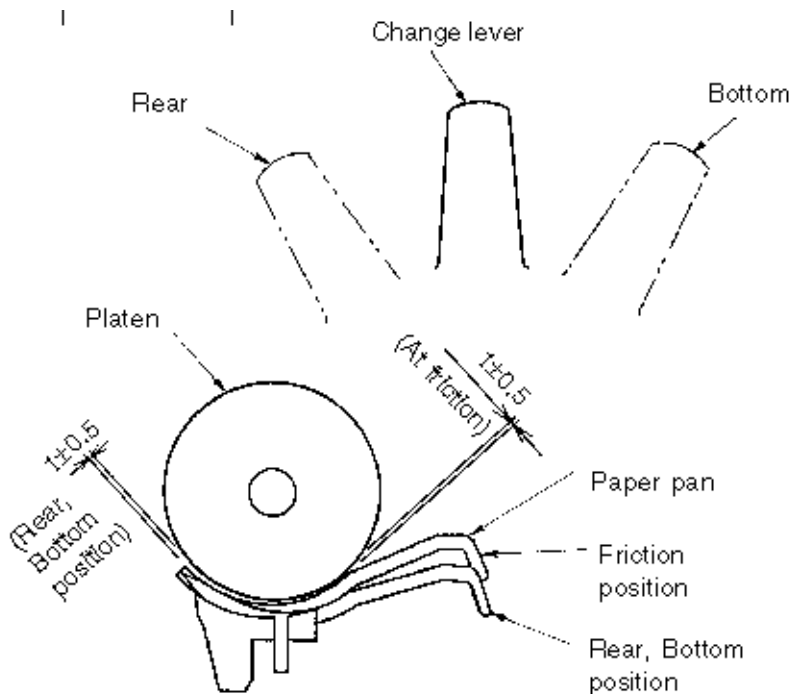

Partner Exchange (BPX) for any updates to this material. (<http://bpx.okidata.com>)

4-3 Gap between the platen and the pressure roller

No.	Item	Specification	Drawing	Adjustment method
4-3	Gap between the platen and the pressure roller		see below	Confirm followings. (1) When the change lever is set at Friction position, all the pressure rollers shall be pressed to the platen. (2) When the change lever is set at Rear or Bottom position, the gap between the platen and the pressure roller at the rear side shall be 3mm. The front pressure rollers shall be pressed to the platen.

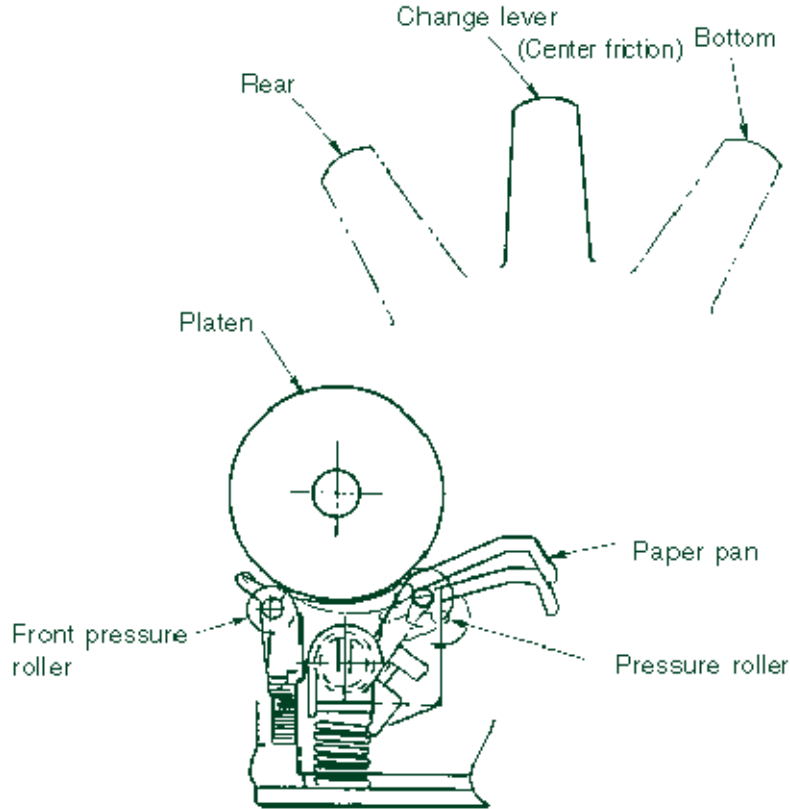

Copyright 1997, Okidata, Division of OKI America, Inc. All rights reserved. See the OKIDATA Business Partner Exchange (BPX) for any updates to this material. (<http://bpx.okidata.com>)

4-4-1 Rotation of the push tractor

To confirm:

The tractor gear shall rotate smoothly when the change lever is set at Friction position.

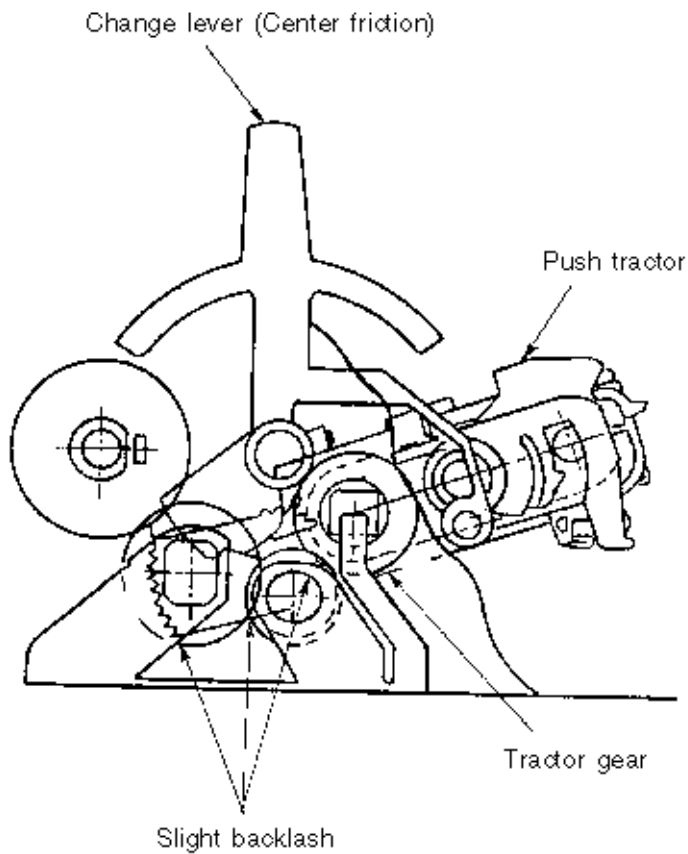

Service Guide ML390/ML391 Turbo
Chapter 4 Adjustments

4-4-2 Backlash between gears

No.	Item	Specification	Drawing	Adjustment method
4-4-2	Backlash between gears	Approx. 0.05 to 0.11 mm		To confirm: There shall be slight backlash between gears to allow smooth rotation of gears. (Backlash 0.05 to 0.11 mm)

4-5-1 Ribbon feed

To confirm:

Ribbon shall be fed smoothly when the carriage is moved from side to side.

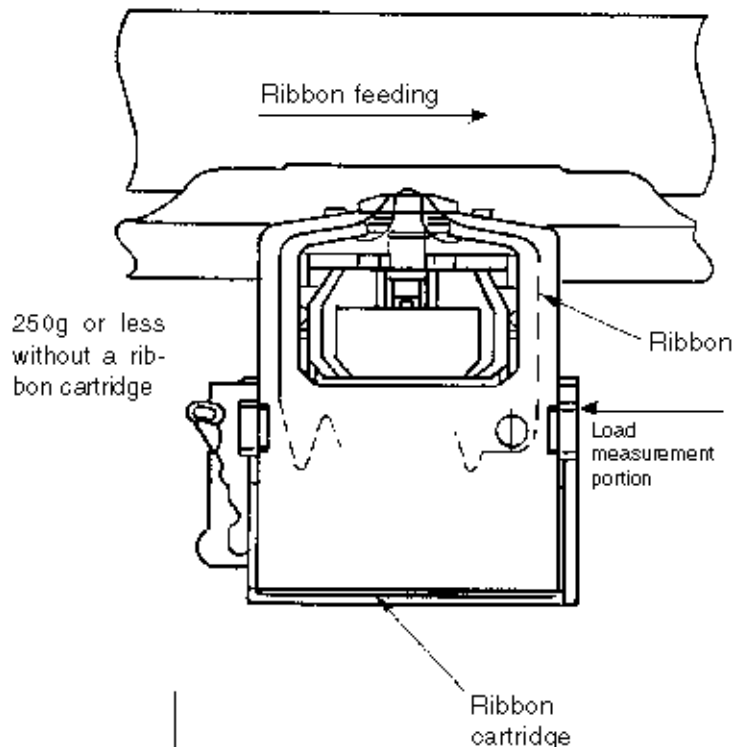

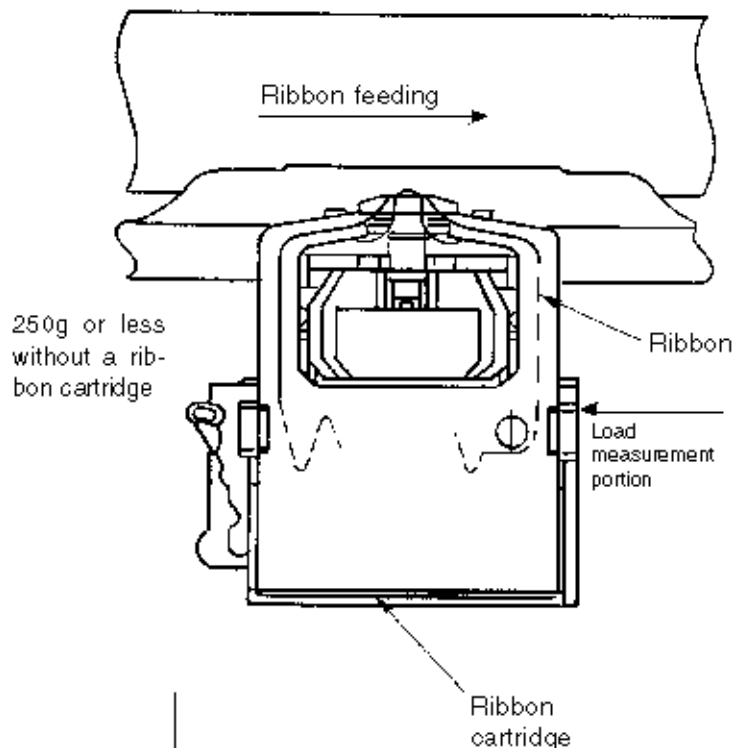
4-5-2 Running load to spacing mechanism**To confirm:****Make sure that the power is turned off at the time of measurement.**

4-6 Engagement of the double gear and the LF motor idle gear of the Platen Assy.

To confirm:

The idle gear of the LF motor and the platen gear (L) and the bias gear of the platen shall be in mesh in such way that the platen gear (L) and the bias gear rotate against each other to pinch the teeth of idle gear.

The idle gear stays in mesh with the platen gear (L) and the bias gear and not locked. The bias gear and the platen gear shall be staggered by one teeth as shown in the drawing.

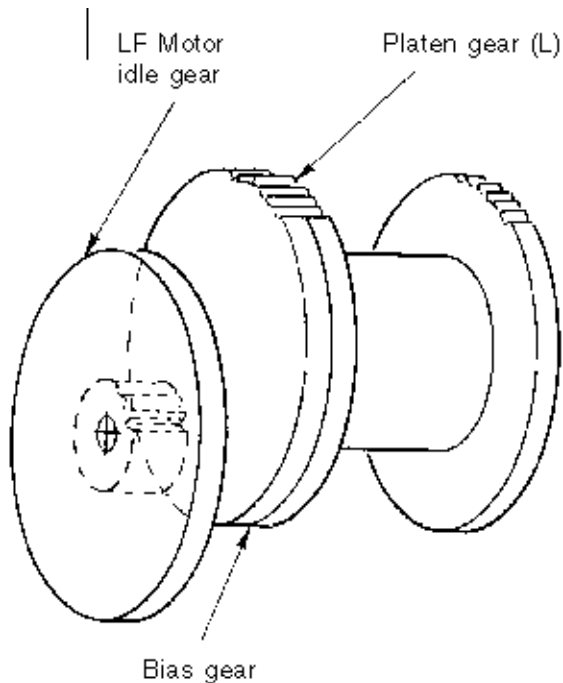

5.1 Cleaning

[Cautions]

1. Be sure to turn OFF the AC POWER switch before cleaning. Remove the AC Power cord from the printer.
2. Avoid dust inside the printer mechanism when cleaning.
3. If a lubricated part has been cleaned, be sure to apply lubricating oil to that portion after cleaning.

(1) Cleaning Time

When the equipment operating time has reached six months or 300 hours, whichever comes first.

(2) Cleaning tools

Dry cloth (soft cloth such as gauze), vacuum cleaner

(3) Places to be cleaned

Table 5.1 lists the places to be cleaned:

Table 5.1

Place to be cleaned	Cleaning procedure
Carriage shaft and the vicinity Paper travel surface	Remove paper waste and wipe off stain, dust, ribbon waste, etc.

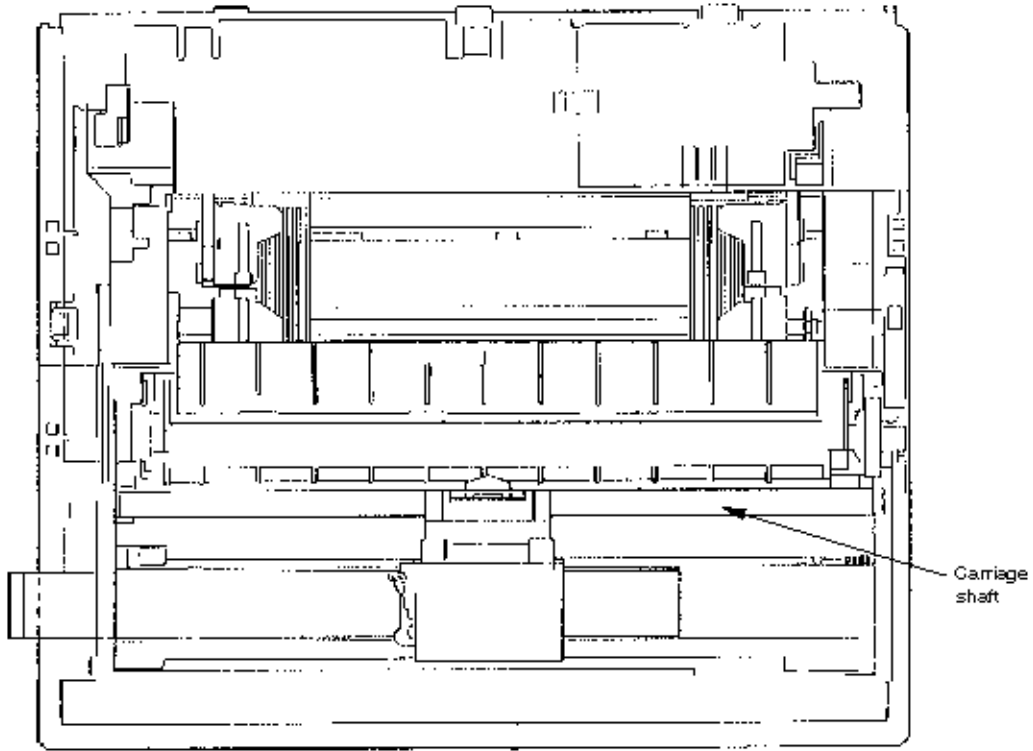

Copyright 1997, Okidata, Division of OKI America, Inc. All rights reserved. See the OKIDATA Business Partner Exchange (BPX) for any updates to this material. (<http://bpx.okidata.com>)



Service Guide ML390/ML391Turbo

Chapter 5 Cleaning and Lubrication

5.2 Lubrication

This printer is designed to be maintenance free and requires no lubrication during normal operation. However it is necessary to apply lubricant in case the printer is disassembled, reassembled, cleaned or parts have been changed.

Copyright 1997, Okidata, Division of OKI America, Inc. All rights reserved. See the OKIDATA Business Partner Exchange (BPX) for any updates to this material. (<http://bpx.okidata.com>)



Service Guide ML390/ML391 Turbo

Chapter 5 Cleaning and Lubrication

(1) Cleaning time

Remarks:

- 1) Turn off the power before cleaning.
- 2) Make sure that paper dust will not fall inside of the machine.

- Cleaning period:

6 months of operation or 300 hours of operation, whichever the earlier.

- Cleaning points:

Carriage shaft and surroundings:	→	Remove paper and ribbon dust.
Paper path:	→	Clean stains and dusts.
Paper End Sensor	→	Remove the dust on the Sensor.

Copyright 1997, Okidata, Division of OKI America, Inc. All rights reserved. See the OKIDATA Business Partner Exchange (BPX) for any updates to this material. (<http://bpx.okidata.com>)



Service Guide ML390/ML391 Turbo

Chapter 5 Cleaning and Lubrication

(2) Lubricant

- Pan motor oil (or equivalent): PM
 - Molicort (or equivalent): EM-30L
-

Copyright 1997, Okidata, Division of OKI America, Inc. All rights reserved. See the OKIDATA Business Partner Exchange (BPX) for any updates to this material. (<http://bpx.okidata.com>)



Service Guide ML390/ML391 Turbo

Chapter 5 Cleaning and Lubrication

(3) Amount of lubricant

- Medium amount A : Apply three to four drops of oil, or 0.008 inch (0.2 mm) thick grease.
 - Small amount B : Apply one drop of oil (0.006±0.002 g)
-

Copyright 1997, Okidata, Division of OKI America, Inc. All rights reserved. See the OKIDATA Business Partner Exchange (BPX) for any updates to this material. (<http://bpx.okidata.com>)



Service Guide ML390/ML391Turbo

Chapter 5 Cleaning and Lubrication

(4) Areas to Avoid

No.	Do not lubricate	Reason	Remarks
1	Platen assembly (rubber face)	To prevent stained paper and illegal paper feed.	
2	Pressure roller (rubber face)	To prevent stained paper	Pay attention not to put the grease on the rubber face of the pressure roller.
3	Carriage shaft	To stabilize carriage traveling load	
4	Ink ribbon image	To prevent blurring of print	
5	Pin tractor	To prevent stained paper	
6	Flexible cable and crack	To prevent loose connection	
7	Motor PCB	To prevent loose connection	
8	Connector terminals	To prevent loose connection	



Service Guide ML390/ML391 Turbo

Chapter 5 Cleaning and Lubrication

(5) Lubrication points -- 1. Ribbon feed gear Assy.

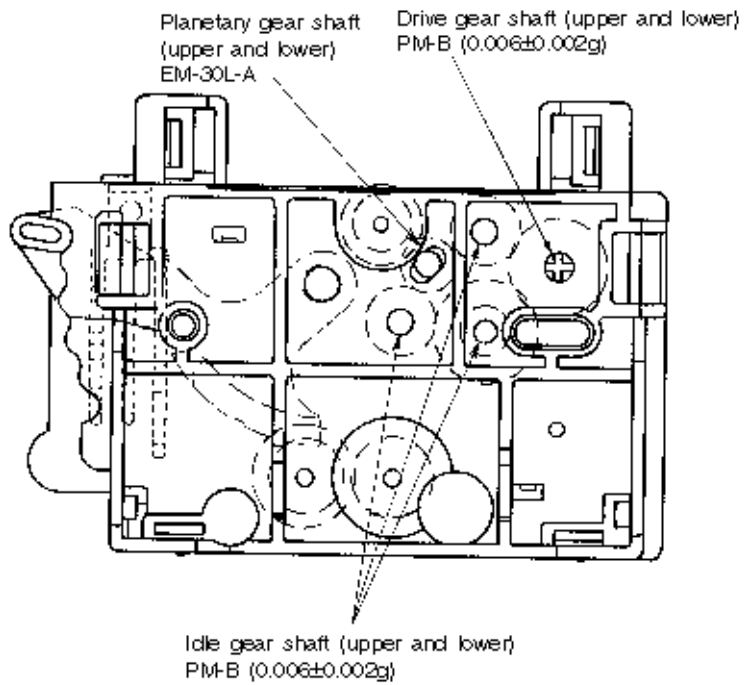



Service Guide ML390/ML391 Turbo

Chapter 5 Cleaning and Lubrication

2. Space rack

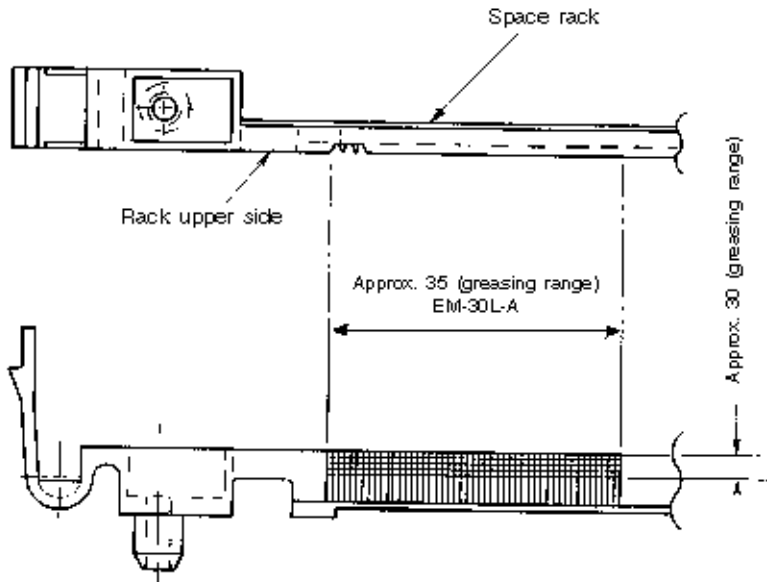

Copyright 1997, Okidata, Division of OKI America, Inc. All rights reserved. See the OKIDATA Business Partner Exchange (BPX) for any updates to this material. (<http://bpx.okidata.com>)

3. Platen Assy.

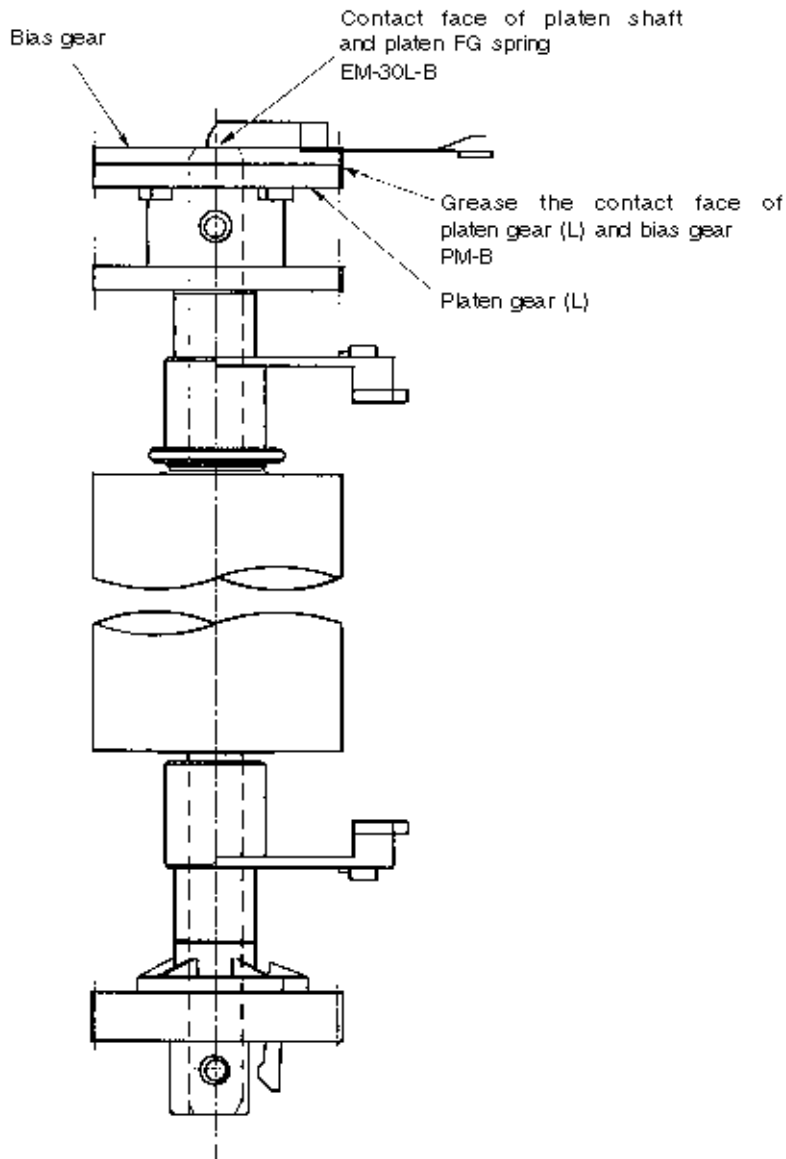

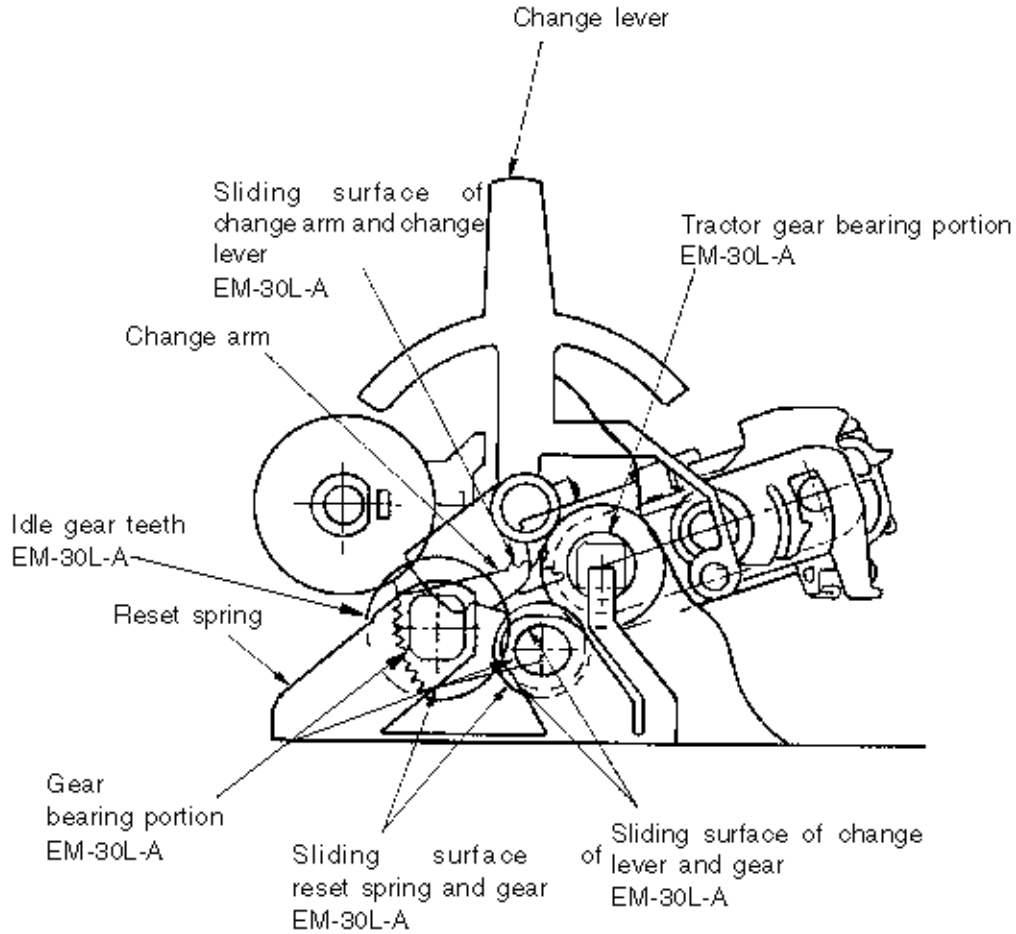
4. Tractor driving mechanism



Service Guide ML390/ML391 Turbo

Chapter 5 Cleaning and Lubrication

5. Tractor drive shaft

Sliding surface of FG spring and drive shaft end
EM-30L-A

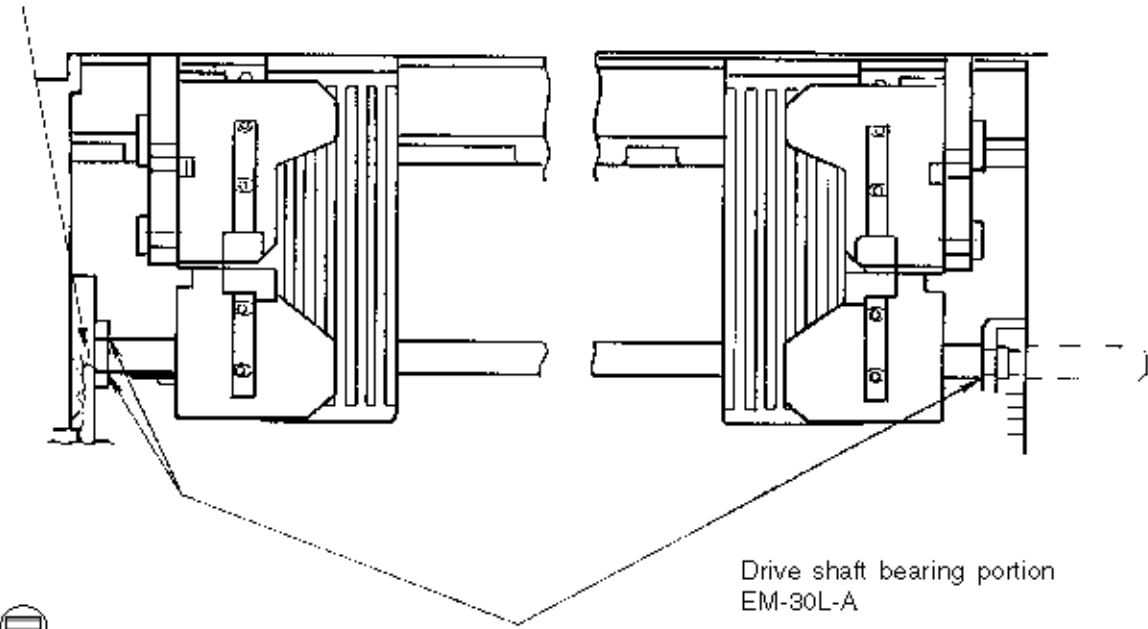

A-A Arrow view

6. Pressure roller

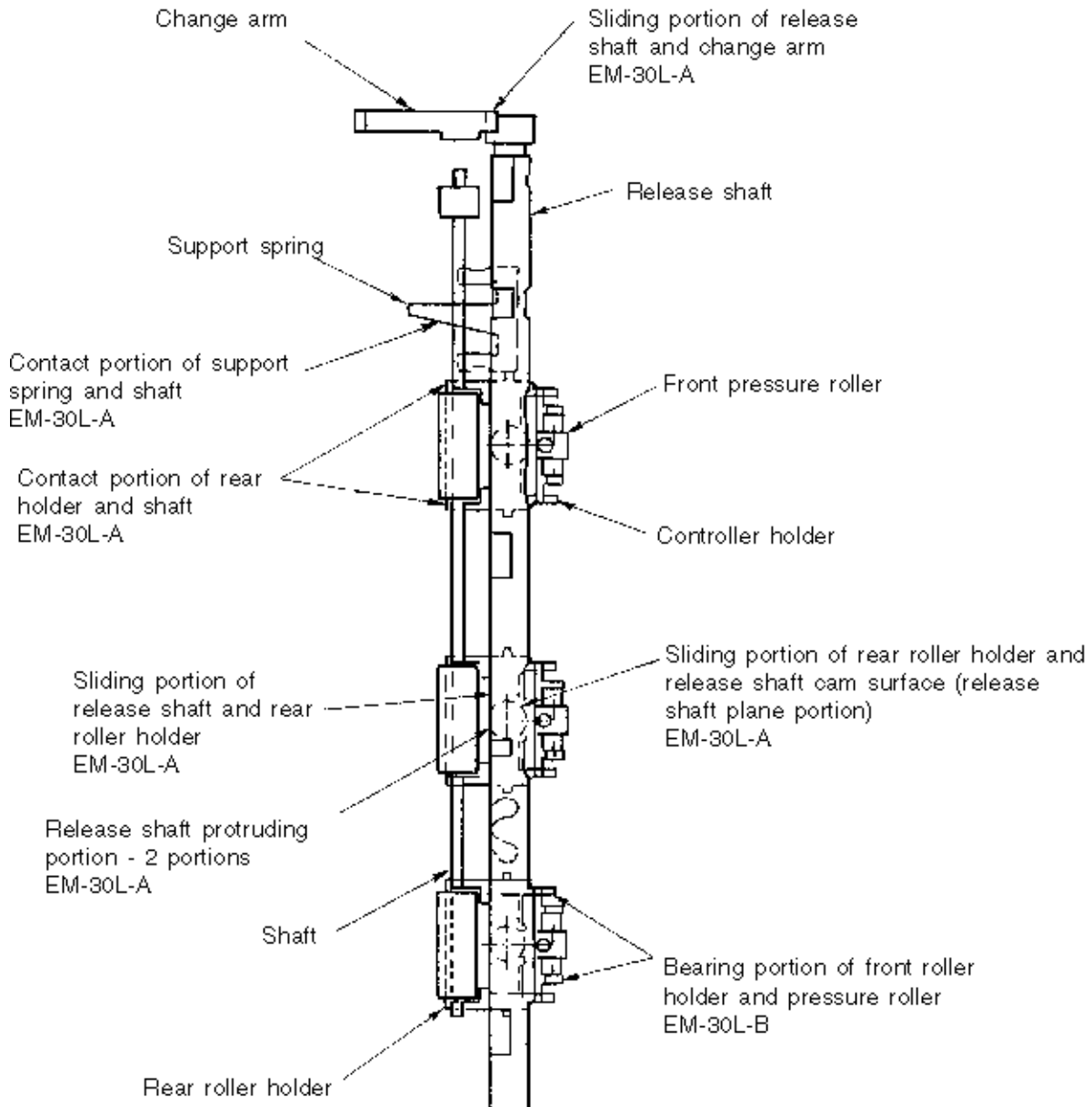



Copyright 1997, Okidata, Division of OKI America, Inc. All rights reserved. See the OKIDATA Business Partner Exchange (BPX) for any updates to this material. (<http://bpx.okidata.com>)

7. Pull up roller Assy.

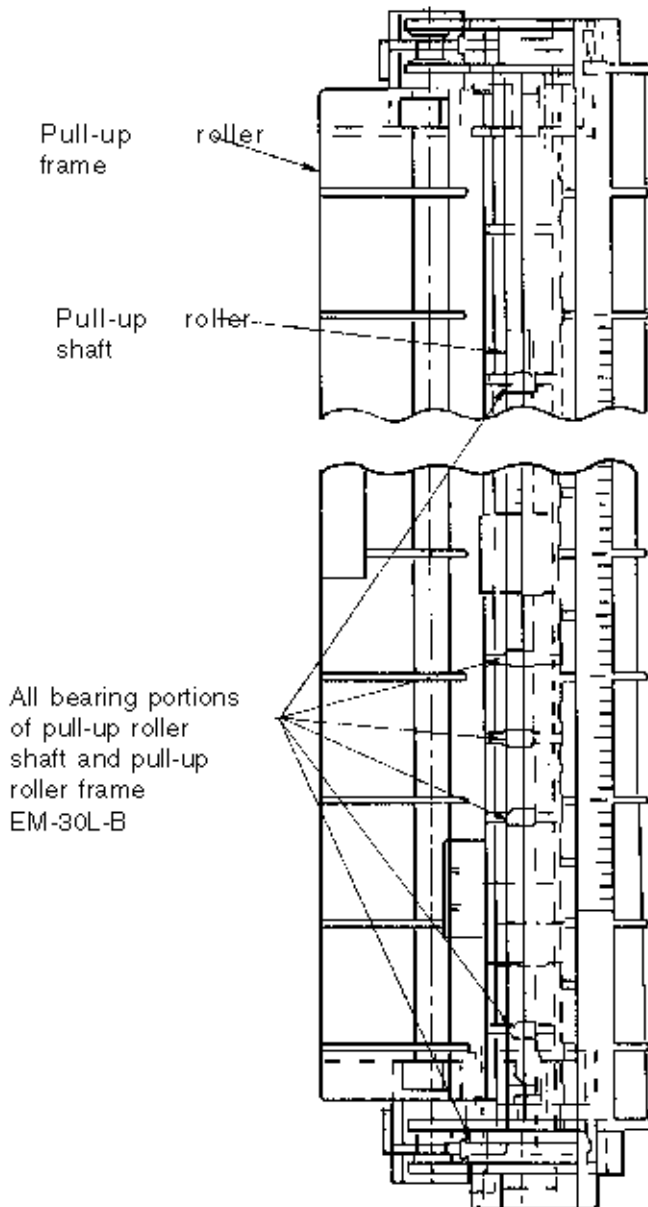

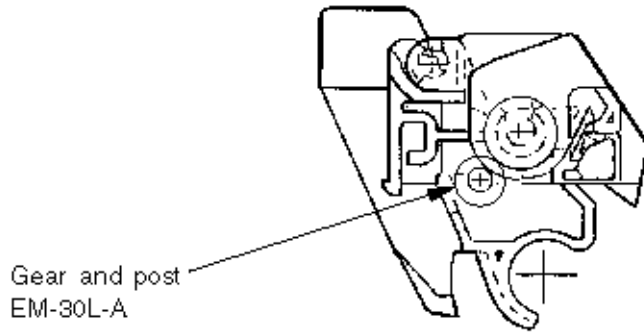

Copyright 1997, Okidata, Division of OKI America, Inc. All rights reserved. See the OKIDATA Business Partner Exchange (BPX) for any updates to this material. (<http://bpx.okidata.com>)



Service Guide ML390/ML391 Turbo

Chapter 5 Cleaning and Lubrication

8. Main chassis Assy.

Grease portion (N: 3 portions, W: 5 portions) rear side
EM-30L-A

Models	
N	ML390 Turbo
W	ML391 Turbo

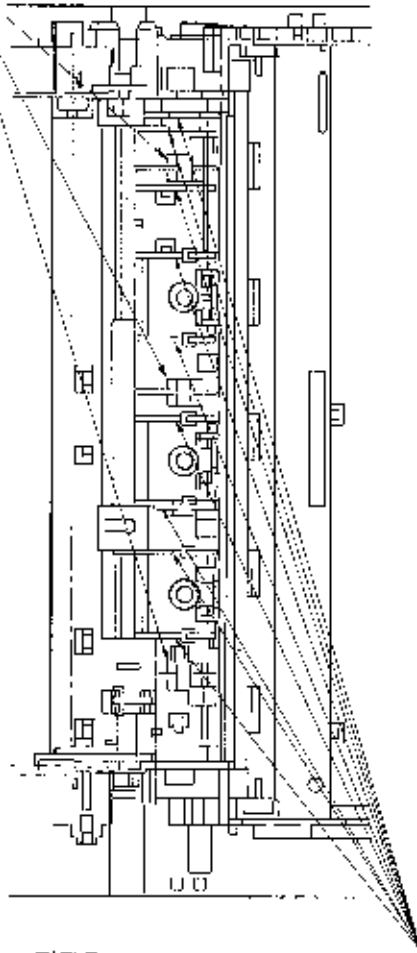

Grease portion at rib
(N: 9 portions W: 13 portions)
EM-30L-A

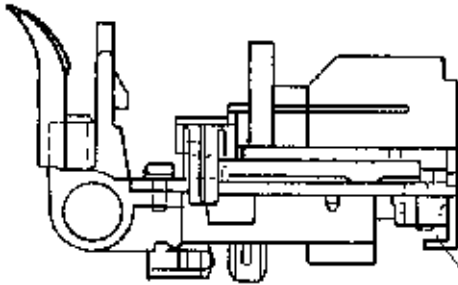
9. Carriage Assy.

NK2-10-SUS Bearing portion
of guide roller
EM-30L-B

6.1 Items to Check Before Repair

- (1) Check the inspection items specified in the instruction manual.
- (2) Find out as many details of the trouble as possible from the customer.
- (3) Inspect in the conditions as close as possible to those at the time the trouble occurred.
- (4) Proceed with the repair as follows:

Check the trouble status according to Table 6.1  for the details of the trouble. Then, locate the trouble position according to the detailed flowchart.

- (5) Carry out a thorough test after the repair to check for correct functioning.
-



Service Guide ML390/ML391Turbo

Chapter 6 Troubleshooting and Repair

6.2 Troubleshooting Table

Status	Trouble Contents	Troubleshooting Flowchart No.	Surmise of Trouble
Trouble upon power on	<ul style="list-style-type: none"> Power is not supplied. 	1	Control/Power Supply Board, Driver Board, Transformer Assy. Space Motor, Carriage Cable, Printhead.
	<ul style="list-style-type: none"> No spacing operation 	2	
	<ul style="list-style-type: none"> Homing does not end normally. 	3	Space Motor, Carriage Cable, Control/Power Supply Board, Driver Board, Spacing Mechanism
Trouble during printing	<ul style="list-style-type: none"> Paper jam while paper insertion 	4	Pressure Roller Mechanism, Pull Up Roller Cover.
	<ul style="list-style-type: none"> Smearing/Missing dots 	5	Printhead, Driver Board, Space Motor, Carriage Cable
	<ul style="list-style-type: none"> Faint or dark print 	6	Printhead, Ribbon Feed Assembly, Driver Board
	<ul style="list-style-type: none"> Ribbon feed trouble 	7	Ribbon Feed Assembly, Space Motor, Driver Board
	<ul style="list-style-type: none"> Line feed trouble 	8	LF Motor, Platen Assy, LF Mechanism, Driver Board
	<ul style="list-style-type: none"> Malfunction of switch on operation panel 	9	Operation Panel, Driver Board
	<ul style="list-style-type: none"> Data receiving failure 	0	Driver Board, (I/F Board), I/F Cable, Menu Setting

6.3 Lamp Display

(1) Printer mode display

Table 6.2

ALARM CATEGORY	ALARM	LED CONDITION					CONTENTS	TROUBLE SHOOTING
		ALARM	SEL	MENU	10CPI	15CPI		
OPERATOR ALARM	Paper end alarm	ON	OFF	—	—	—	From, cut sheet or bottom paper end	Set New paper.
	Paper change lever alarm	ON	OFF	—	BLINK 1	OFF	Change lever is set to TOP position while paper is already inserted from rear or bottom.	+ Set the lever to specified position. + Check rear sensor lever. + Replace Control Board
	Paper jam alarm	ON	OFF	—	OFF	BLINK 1	+ Cut sheet could not be ejected. + Cut sheet could not be fed properly	+ Remove the paper or check feed Mechanism + Press SEL key.
	Print Head thermal alarm	OFF	—	BLINK 1	—	—	Print head temperature exceeds 119°C	+ Wait until it is cooled. + Replace P.H. or Driver Board
	Spice motor thermal alarm	OFF	—	BLINK 1	—	—	Temperature of spice motor exceeds specified value.	+ It is recovered automatically + Replace SP motor or Driver Board
FATAL ALARM		BLINK 2	OFF	OFF	See Table 6.3		Hardware Alarm has occurred.	See Table 6.3.

Note: BLINK1 : 400ms ON, 400ms OFF BLINK2 : 200ms ON, 200ms OFF — : LED is kept in Current Condition (no change)

(2) Fault alarm display

When the printer detects any of the various alarm states, the information is displayed as shown below on the operation panel.

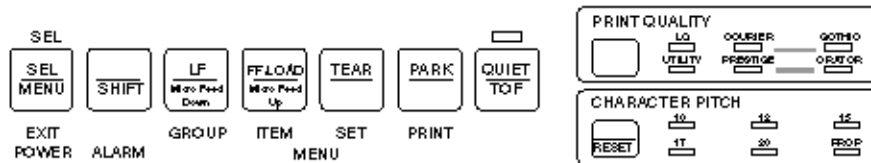

Figure 6-1

Table 6.3 (1/2)

ALARM CATEGORY	ALARM	LED DISPLAY										REMARKS	TROUBLESHOOTING	
		ALARM	10	12	15	17	20	PROP	UTILITY	PRESTAGE	OPERATOR			
MAIN CONTROL ALARM	MPU internal RAM alarm	⊗	○										Read/write error	Replace Control/Power Supply Board
	Program ROM alarm	⊗			○								Check sum error	Replace ROM or Control/Power Supply Board
	RAM on Control Board alarm	⊗					○						Read/write error	Replace Control/Power Supply Board
	CG ROM alarm	⊗			○					○			Check sum error	Replace Control/Power Supply Board
	EEPROM alarm	⊗			○						○		No reaction when MPU reads data	Replace Control/Power Supply Board
FIRMWARE DETECTION ALARM	WDT (Watch Dog Timeout) alarm	⊗				○							MPU is locked up and it is reset after 65ms.	Turn the power OFF and ON or replace Control/Power Supply Board
	NMI signal alarm	⊗				○			○				NMI port of MPU is kept low level.	Turn the power OFF and ON or replace Control/Power Supply Board
	BRK instruction alarm	⊗				○				○			FFFF data is detected due to MPU locked up.	Replace ROM or Control/Power Supply Board
SERIAL INTERFACE ALARM	MPU internal RAM alarm	⊗	○						○				Read/write error	Replace I/F Board
	ROM alarm	⊗			○				○				Check sum error	Replace ROM on I/F board or I/F Board
	RAM on I/F board alarm	⊗					○		○				Read/write error	Replace I/F Board
	I/F not mounted	⊗		○					○				No reaction from serial I/F board	Replace I/F Board or Control Board.

⊗ : LED Blink (200ms ON, 200ms OFF)
○ : LED Lights up

Table 6.3 (2/2)

ALARM CATEGORY	ALARM	LED DISPLAY										REMARKS	TROUBLESHOOTING	
		ALARM	10	12	15	17	20	PROP	UTILITY	PRESTAGE	OPERATOR			
SPACING ALARM	Spacing alarm	⊗						○	○				Space IPT is not occurred within in specified timing.	<ul style="list-style-type: none"> • Replace space motor. • Replace P.H. cable. • Replace Control/Power Supply Board
	Print Head homing alarm	⊗						○		○			Print head does not reach to the home position.	<ul style="list-style-type: none"> • Check the mechanism if load is too much.
PRINT HEAD ALARM	Print Head A/D alarm	⊗	○				○						Thermister is open, short with 0V or short with +5V.	<ul style="list-style-type: none"> • Check the P.H. connection. • Replace Print Head. • Replace P.H. cable. • Replace Control/Power Supply Board
	Print Head Gap A/D alarm	⊗	○				○		○				Print Head Gap Signal open	<ul style="list-style-type: none"> • Replace P.H. cable. • Replace Space Motor Assy. • Replace Control/Power Supply Board

⊗ : LED Blink (200ms ON, 200ms OFF)
○ : LED Lights up

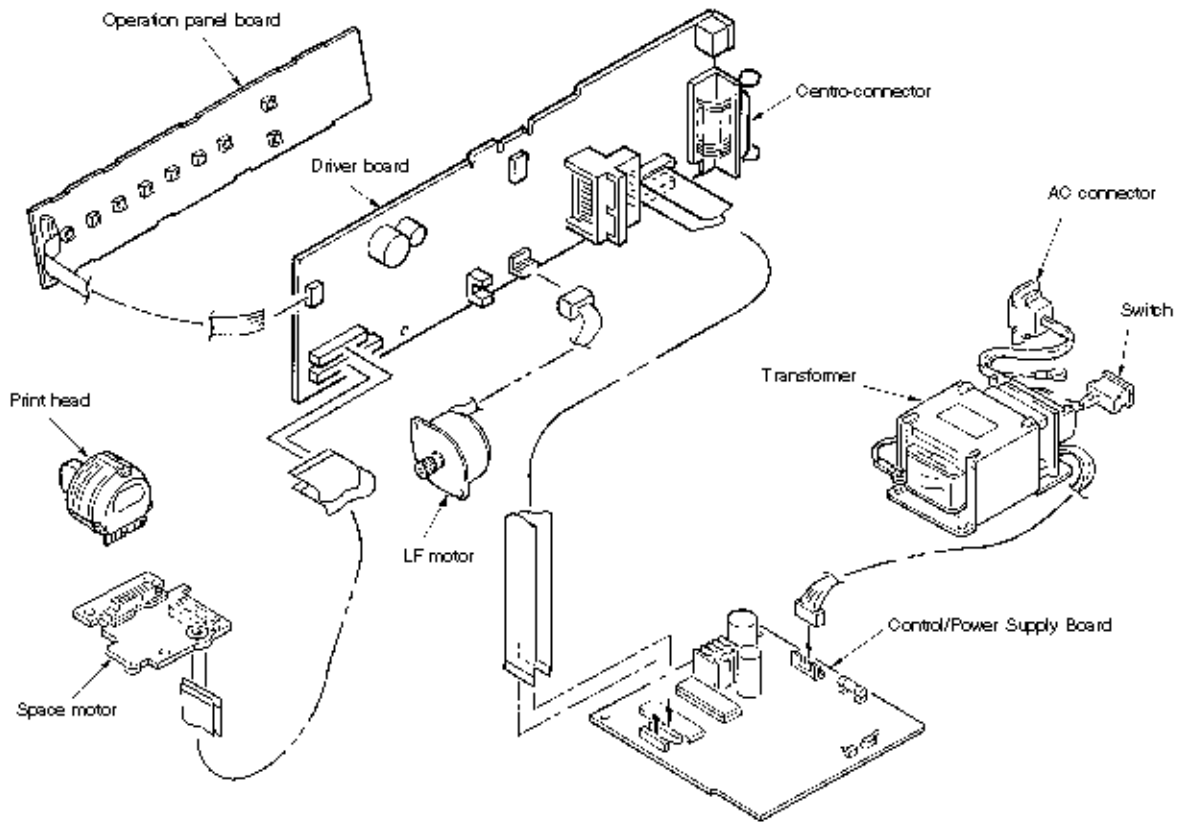

Copyright 1997, Okidata, Division of OKI America, Inc. All rights reserved. See the OKIDATA Business Partner Exchange (BPX) for any updates to this material. (<http://bpx.okidata.com>)



Service Guide ML390/ML391 Turbo

Chapter 6 Troubleshooting and Repair

6.4 Connection Circuit Check for Printhead and SP/LF Motor

(1) Printhead

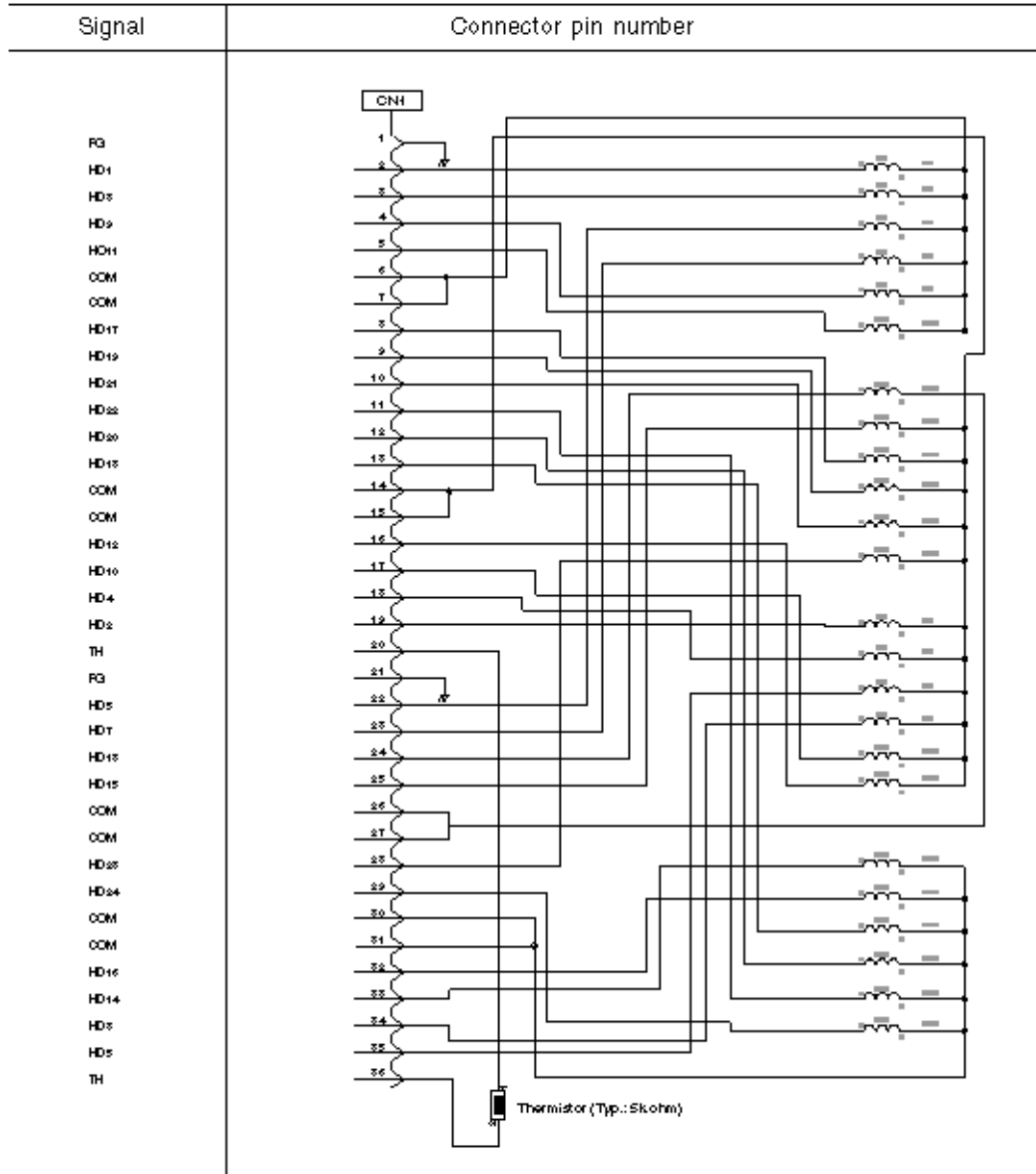

(2) Line Feed Motor

Resistance of each coil should be about 7.6 Ohms.

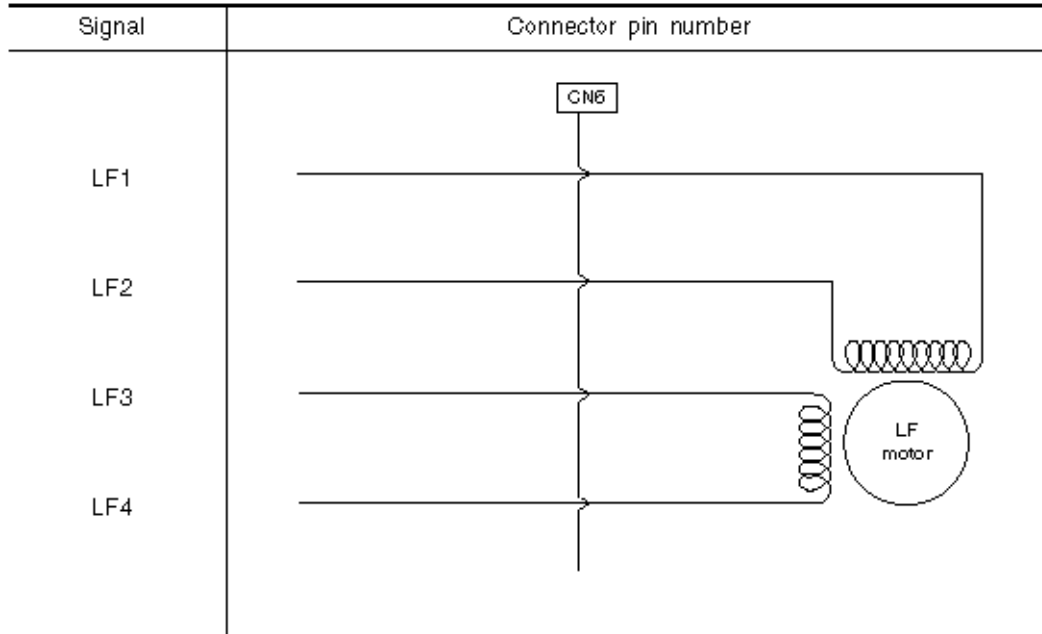



Service Guide ML390/ML391 Turbo

Chapter 6 Troubleshooting and Repair

(3) Space Motor

Resistance of each coil should be about 5 Ohms.

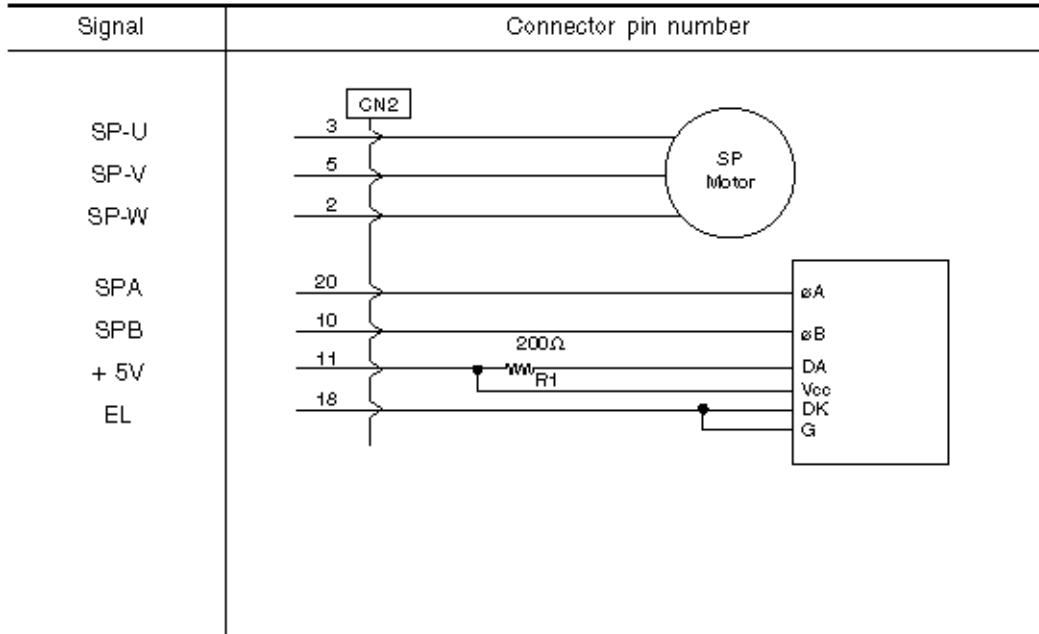



Service Guide ML390/ML391 Turbo

Chapter 6 Troubleshooting and Repair

6.5 Troubleshooting Flow Charts

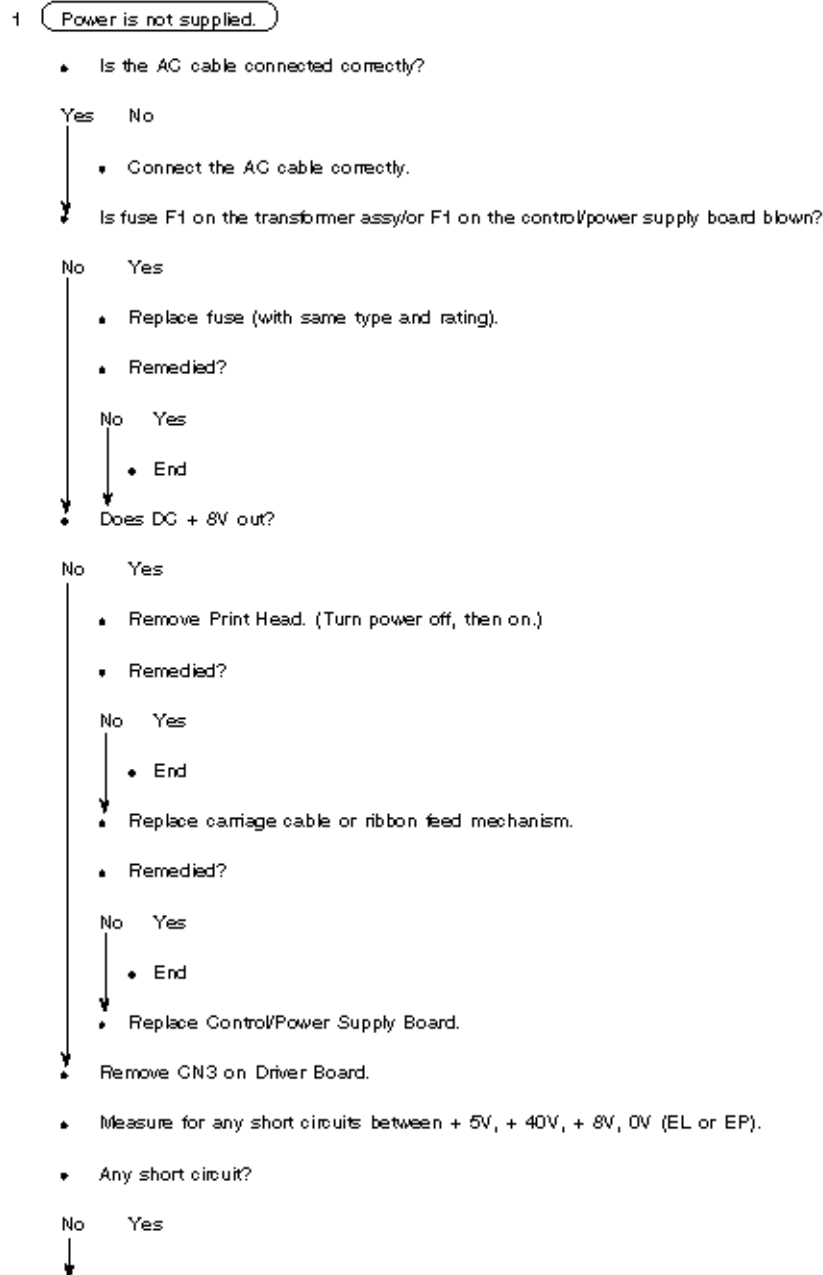

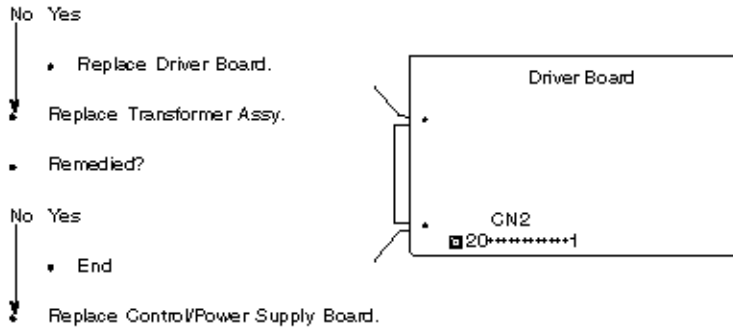

Pin No.	20	19	18	17	16	15	14	13	10	9	8	7	6	5
Signal	+8V	EP (F.G)		+40V	AC 10V	EL (0V)	+5V							

Copyright 1997, Okidata, Division of OKI America, Inc. All rights reserved. See the OKIDATA Business Partner Exchange (BPX) for any updates to this material. (<http://bpx.okidata.com>)



Service Guide ML390/ML391 Turbo

Chapter 6 Troubleshooting and Repair

2 No Spacing Operation (The Alarm LED Blinks)

2 No spacing operation (The alarm LED Blinks)

- Is carriage assembly binding or jammed?
- No Yes
- ↓
- Check around space motor to repair the mechanism of space rack, back up roller, ribbon feed mechanism, and carriage frame etc.
- ↓
- Replace space motor assy.
- Remedied?
- No Yes
- ↓
- End
- ↓
- Replace Driver Board.
- Remedied?
- No Yes
- ↓
- End
- ↓
- Replace carriage cable.
-



Service Guide ML390/ML391 Turbo

Chapter 6 Troubleshooting and Repair

3 Homing does not end normally

3 Homing does not end normally

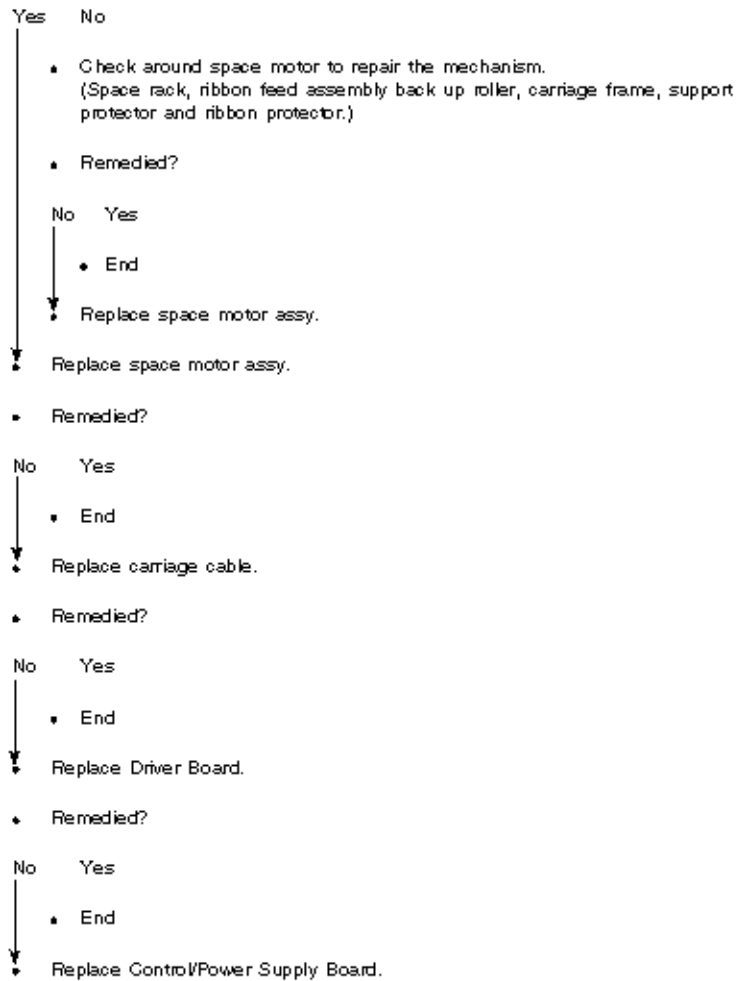

4 Paper jam while paper insertion

4 Paper jam while paper insertion

Jam 1



- Check the ribbon protector.
- Check the pull up roller cover is closed properly.

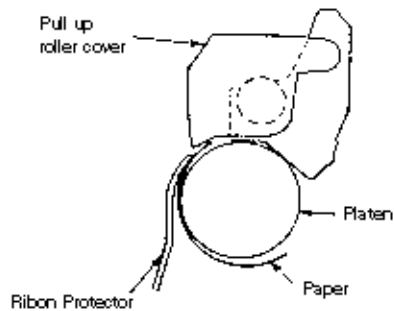

Jam 2 (wrinkled paper)

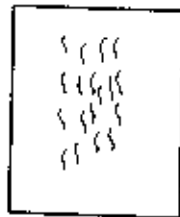

- Check around pressure roller mechanism.
 - + Front pressure springs are narrow: 3 pcs; wide: 5 pcs) mounted properly or not.
 - + Tension of all of front pressure rollers is properly.
 - + Make sure of the fitting position of change gear shaft, change arm shaft and release shaft are correct.
-



Service Guide ML390/ML391 Turbo

Chapter 6 Troubleshooting and Repair

5 Smearing/Missing Dots

5 Smearing/Missing Dots

- Does ALARM LED blink and display alarm?

No Yes

↓

- See Tables 6.2 and 6.3 for troubleshooting information.
- Replace Printhead.

- Remedied?

No Yes

↓

- End
- Replace Driver Board.

- Remedied?

No Yes

↓

- End
 - Replace carriage cable or space motor assembly.
-



Service Guide ML390/ML391 Turbo

Chapter 6 Troubleshooting and Repair

6 Faint or dark print

6 Faint or dark print

- Is the print head gap set properly?

Yes No

- Adjust the print head gap (see section 5).

- Remedied?

No Yes

- End

- Replace Printhead.

- Remedied?

No Yes

- End

- Replace Driver Board.

- Remedied?

No Yes

- End

- Replace ribbon feed mechanism.
-

7 Ribbon feed trouble**7** Ribbon feed trouble

- Remove the ribbon cartridge.
- Move carriage to left and right.
- Does the ribbon drive shaft rotate?

No Yes



- Change ribbon cartridge.
- Remove ribbon feed mechanism.

- Move carriage to left and right.
- Does the ribbon drive shaft rotate?

No Yes



- Replace ribbon feed mechanism.
 - Replace space motor assy.
-



Service Guide ML390/ML391 Turbo

Chapter 6 Troubleshooting and Repair

8 Line feed trouble

8 Line feed trouble

- Turn the power off, and rotate the platen manually.
- Does the platen rotate smoothly?

Yes No

- Is the platen gear (L) broken?

No Yes

- Replace platen assembly.

- Is the LF motor idle gear broken?

No Yes

- Replace the LF motor assembly or LF idle gear.

- Is the platen gear (R), idle gear or change gear broken?

No Yes

- Replace the gear.

- Set change lever to the rear position.

- Does the platen rotate smoothly?

No Yes

- Replace tractor feed assembly.

- Replace LF motor assembly.

- Replace LF motor assembly.

- Remedied?

No Yes

- End

- Replace Driver Board.



Service Guide ML390/ML391 Turbo

Chapter 6 Troubleshooting and Repair

9 Malfunction of switch on operation panel

9 Malfunction of switch on operation panel

- Is the CN1 of operation panel connected to the CN3 on the Driver Board?

Yes No



- Connect the cable properly.
- Replace Operation Panel Board.

- Remedied?

No Yes



- End
 - Replace Driver Board.
-

10-2 (RS232C I/F)

Printer I/F pin assignment.

TXD	2 pin,
RXD	3 pin,
SSD	11 pin,
DTR	20 pin,
DSR	6 pin.

Is the correct cable used?

Yes No

- Change I/F cable.

Is ALARM LED blinking?

No Yes

- See tables 6.2 and 6.3 for the troubleshooting.
- Make sure of the parameters for RS232C in the menu are correct.

- Baud rate
- Bit length
- Parity
- Protocol
- Busy signal and its polarity

- Remedied?

No Yes

- End

Is +8V supplied on Driver Board?

Yes No

Remove RS232C I/F Board.

- Is the +8V supplied on the Driver Board?

No Yes

Replace RS232C I/F Board.

Replace Driver Board.

Replace RS232C Board.

- Remedied?

No Yes

- End

Replace Driver Board.

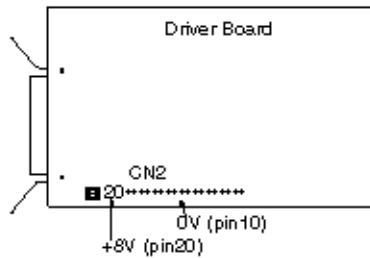



Service Guide ML390/ML391 Turbo

Chapter A PCB Layout

APPENDIX A: PCB LAYOUT

PCB List

- (1) Circuit board SRXC (Control/Power Supply)
- (2) Circuit board SRXD (Driver)
- (3) Circuit board LEOP (Operation Panel)

(1) Control/Power Supply Board (SRXC)

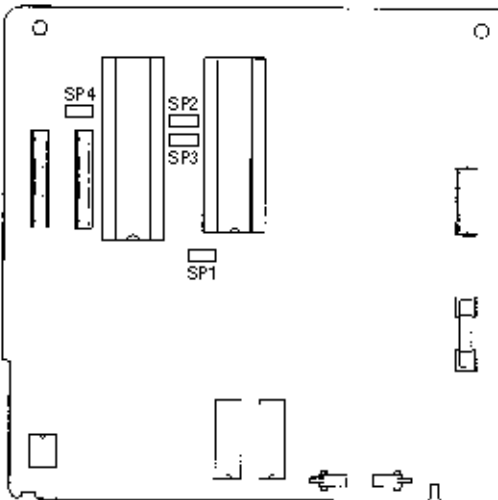

Short Plug	Setting	Default
SP1 	1 - 2: 4 Mbit EPROM 2 - 3: 1 M/2 Mbit EPROM	1 - 2
SP2 SP3 	SP2 (A) - (B) and SP3 (A) - (B): To use program ROM of Q1. SP2 (A) - SP3 (A) and SP2 (B) - SP3 (B): To use program ROM of Q2.	SP2 (A) - (B) and SP3 (A) - (B)
SP4 	1 - 2: 2 - 3: No relation for any setting. Do not change default setting.	1 - 2

(2) Driver Board (SRXD)

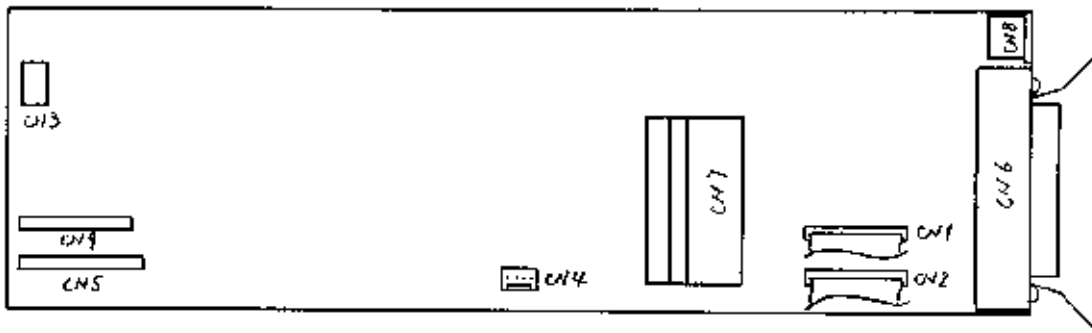

(3) Operation Panel Board (LEOP)

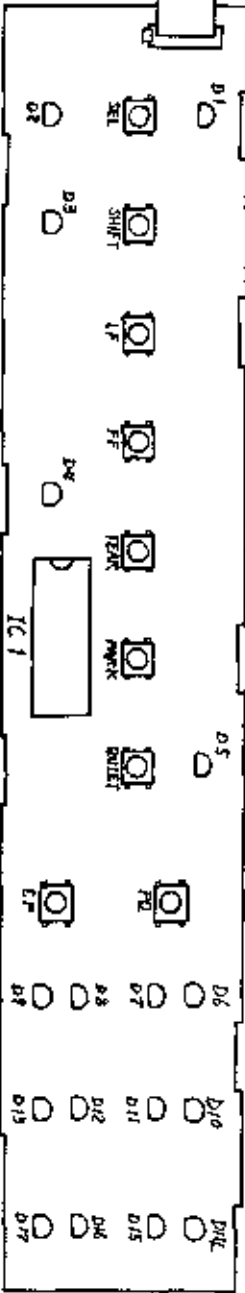

Copyright 1997, Okidata, Division of OKI America, Inc. All rights reserved. See the OKIDATA Business Partner Exchange (BPX) for any updates to this material. (<http://bpx.okidata.com>)



Service Guide ML390/ML391 Turbo

Chapter B Parts Listing

SPARE PARTS LIST

Quantity per year: Indicates the recommended number of each part that should be ordered for routine maintenance for one year for 500 units of printers and assuming that the printers are operated for 2 hours/day or 730 hours/year. The following codes are used to indicate the number of printers for which maintenance parts are ordered.

Copyright 1997, Okidata, Division of OKI America, Inc. All rights reserved. See the OKIDATA Business Partner Exchange (BPX) for any updates to this material. (<http://bpx.okidata.com>)

Upper Cover Assembly (Figure 11-1)

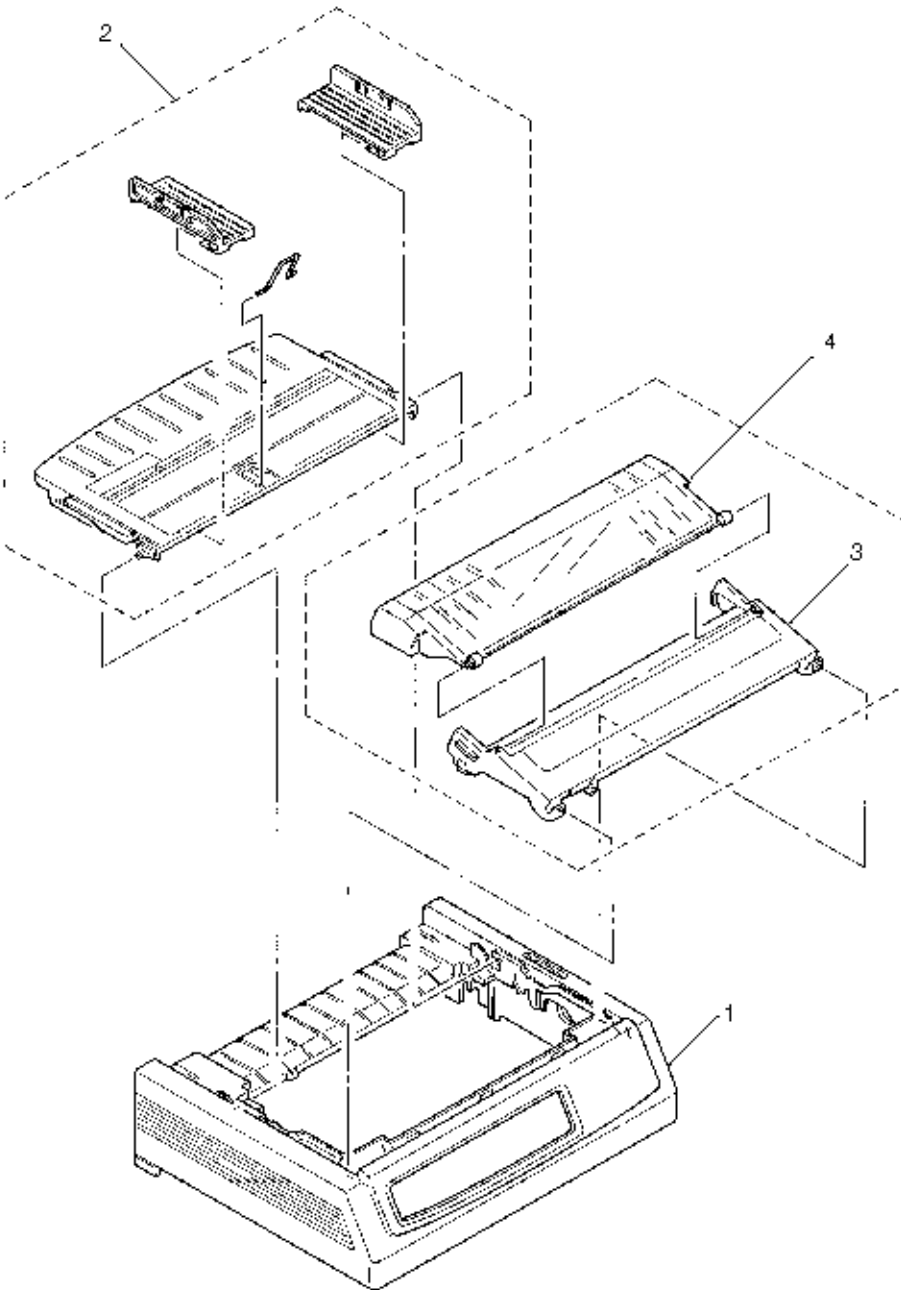

No.	Part No.	Description	Q'ty	Remarks	ODA#
1	1PP4128-1186P1	Cover: Upper (N)	1	For ML390 Turbo	53076501

	1PP4128-1231P1	Cover: Upper (W)	1	For ML391 Turbo	53076601
2	1PA4094-7305G10	Guide: Sheet Assy (N)	1	For ML390 Turbo	51009409
	1PA4094-7308G11	Guide: Sheet Assy (W)	1	For ML391 Turbo	51009510
3	2PA4128-1237G1	Cover: Access Assy (N)	1	For ML390 Turbo	53076701
	2PA4128-1241G1	Cover: Access Assy (W)	1	For ML391 Turbo	53076801
4	1PP4128-1188P1	Cover: Acoustic (N)	1	For ML390 Turbo	53076901
	1PP4128-1233P1	Cover: Acoustic (W)	1	For ML391 Turbo	53077001

Copyright 1997, Okidata, Division of OKI America, Inc. All rights reserved. See the OKIDATA Business Partner Exchange (BPX) for any updates to this material. (<http://bpx.okidata.com>)

Printer General Assembly (Figure 11-2)

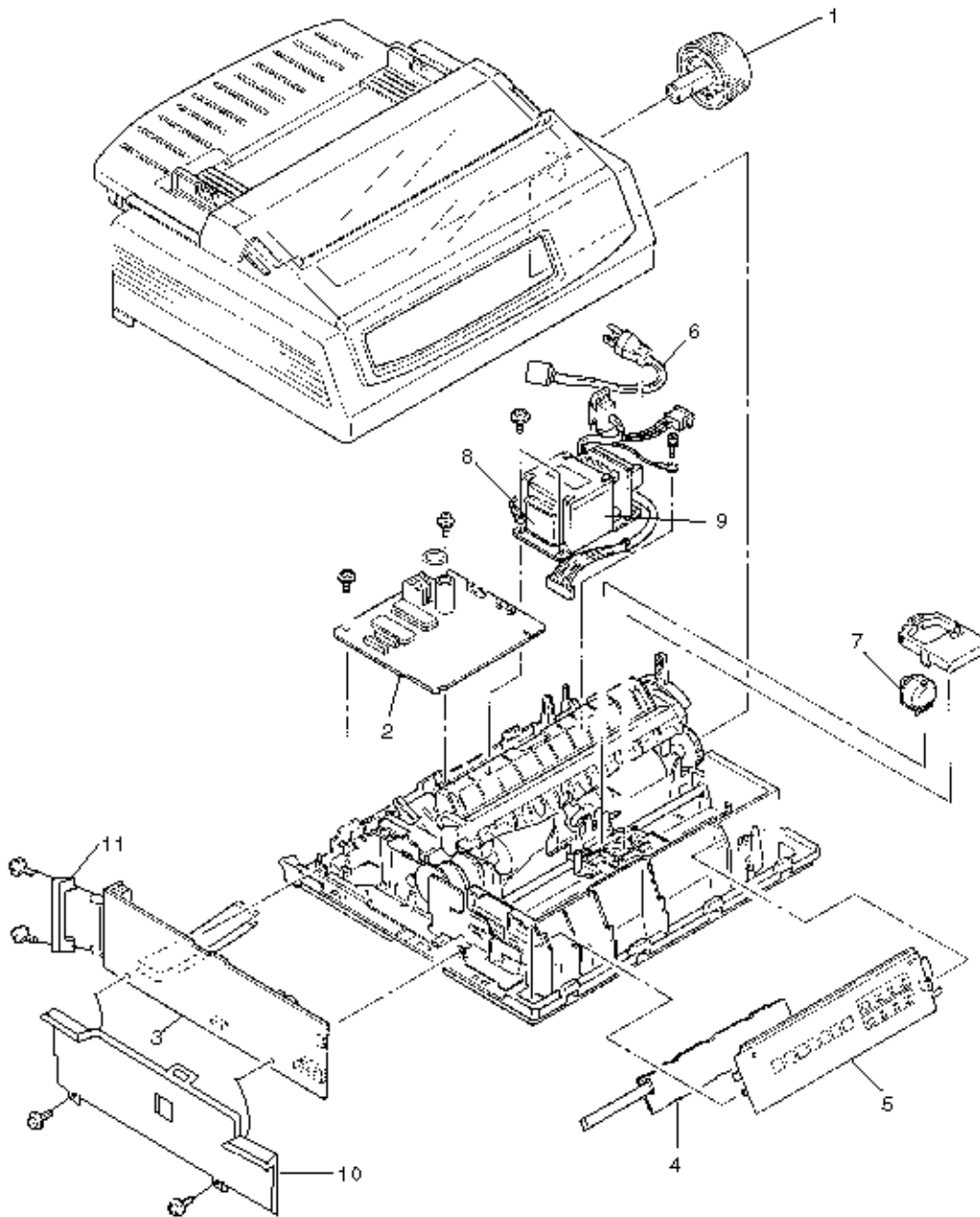

No.	Part No.	Description	Qty	Remarks	ODA#
1	3PP4025-2871P21	Knob: Platen	1		51902220

2	4YA4042-1545G301	PCB: SRXC (without ROM) (Control/Power supply)	1	Without ROM	55080901
3	4YA4042-1544G1	PCB: SRXD (without ROM) (Driver Board)	1	Without ROM	55081001
4	4YA4042-1516G4	PCB: LEOP-4	1		55081104
5	3PP4044-5360G2	Operator Panel Assembly	1		50221902
6		AC cord for 120V	1	for ODA	56631804
		AC cord for 220V	1		56631901
7	4YA4023-3101G1	Printhead (Assy) (24)	1		50114701
8	40085501	Fuse (125V 2.5A)	2	For 120V	40085501
	4YB4042-1551P1	Fuse (250V 1.25A)	1	For 230/240V	56307201
9	4YB4049-7105P1	(ML390 Turbo 120V)	1		56415501
	4YB4049-7106P1	Transformer (ML390 Turbo 230/240V)	1		56415601
	4YB4049-7105P2	Transformer (ML391 Turbo 120V)	1		56415502
	4YB4049-7106P2	Transformer (ML391 Turbo 230/240V)	1		56415602
10	3PB4050-3429P1	PCB plate	1		51022801
11	40045601	FG plate	1		51023501

Copyright 1997, Okidata, Division of OKI America, Inc. All rights reserved. See the OKIDATA Business Partner Exchange (BPX) for any updates to this material. (<http://bpx.okidata.com>)

Printer Unit (Figure 11-3) [1 of 2]

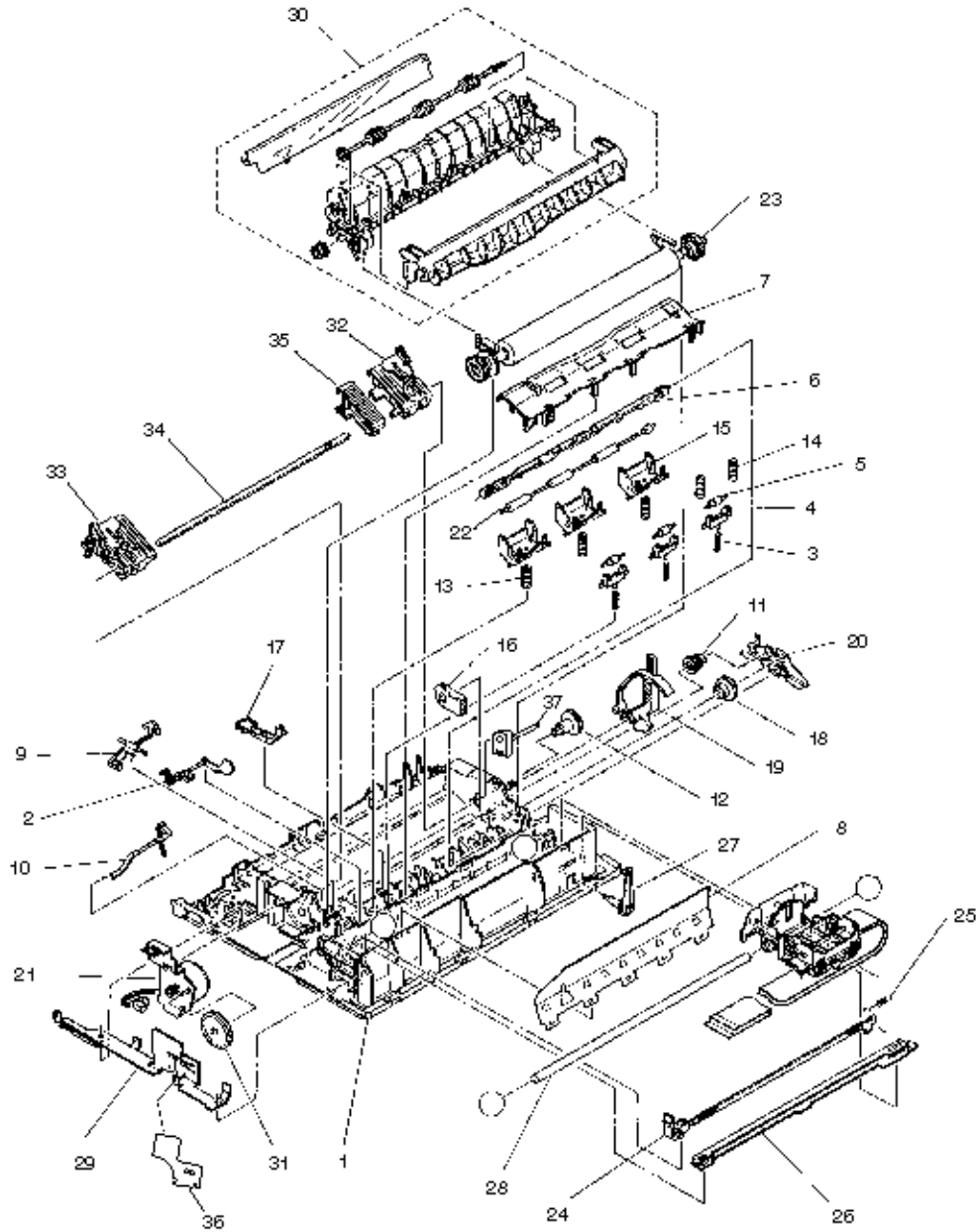

No.	Part No.	Description	Qty	Remarks	ODA#
-----	----------	-------------	-----	---------	------

1	3PA4044-5002G2	Frame: Main Assy (N)	1	For ML390 Turbo	53348801
	3PA4044-5152G2	Frame: Main Assy (W)	1	For ML391 Turbo	53348901
2	3PP4044-5012P1	Lever: Bottom Paper End	1		50809201
3	4PP4044-5019P1	Spring: Pressure (F) N	3	For ML390 Turbo	50931301
	4PP4044-5019P2	Spring: Pressure (F) W	5	For ML391 Turbo	50931302
4	4PP4044-5031P1	Holder: Roller (F)	3	For ML390 Turbo	53349001
			5	For ML391 Turbo	53349001
5	4PA4025-3327G2	Roller: Front Pressure Assy	3	For ML390 Turbo	50410901
			5	For ML391 Turbo	50410901
6	3PP4044-5015P1	Shaft: Release (N)	1	For ML390 Turbo	51114001
	3PP4044-5157P1	Shaft: Release (W)	1	For ML391 Turbo	51114101
7	1PP4044-5021P1	Plate: Paper Pan (N)	1	For ML390 Turbo	53349201
	1PP4044-5158P1	Plate: Paper pan (W)	1	For ML391 Turbo	53349301
8	3PP4025-3320P2	Spring: Leaf (N)	1	For ML390 Turbo	50923002
	3PP4025-3507P2	Spring: Leaf (W)	1	For ML391 Turbo	50923102
9	3PP4044-5011P1	Lever: Paper End	1		50809301
10	3PP4044-5013P1	Lever: Sensor	1		50809401
11	4PP4025-3340P1	Gear: Change	1		51228001
12	3PP4025-3341P1	Gear: Tractor	1		51228101
13	4PP4044-5020P1	Spring: Pressure (R)	3	For ML390 Turbo	50931401
			3	For ML391 Turbo	50931401
14	4PP4044-5163P1	Spring: Pressure (W)	2	For ML391 Turbo	50931501
15	3PP4044-5033P1	Holder: Roller (R)	3	For ML390 Turbo	53349101
			5	For ML391 Turbo	53349101
16	4PP4044-5017P1	Arm: Change	1		50809701
17	3PP4044-5014P1	Lever: Switch	1		50809601
18	4PP4044-5024P1	Gear: Idle	1		51238501
19	2PP4044-5016P1	Lever: Change	1		50809501
20	3PP4044-5023P1	Spring: Reset	1		50931601
21	3PA4044-5110G2	Motor: LF (Assy)	1		56513602
22	3PP4044-5034P1	Roller: Rear pressure (N)	1	For ML390 Turbo	53349401
	3PP4044-5162P1	Roller: Rear pressure (W)	1	For ML391 Turbo	53349501



Service Guide ML390/ML391Turbo

Chapter B Parts Listing

Printer Unit (Figure 11-3) [2 of 2]

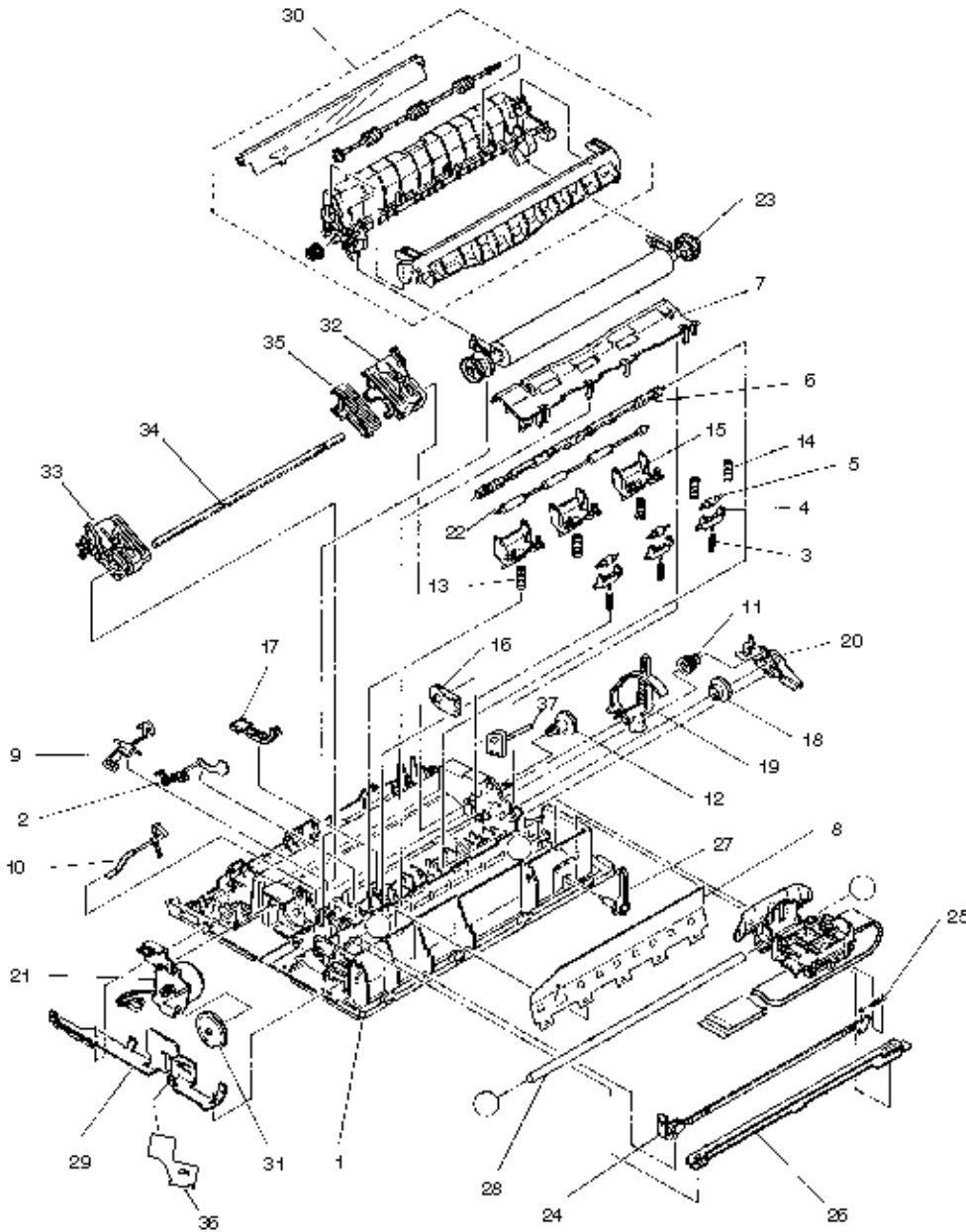

No.	Part No.	Description	Q'ty	Remarks	ODA#
23	3PA4044-5025G2	Assembly: Platen (N)	1	For ML390 Turbo	50114801

	3PA4044-5159G2	Assembly: Platen (W)	1	For ML391 Turbo	50114901
24	3PP4044-5010P1	Rack: Space (N)	1	For ML390 Turbo	53349601
	3PP4044-5156P1	Rack: Space (W)	1	For ML391 Turbo	53349701
25	4PB4025-3377P2	Spring:Tension(SpaceRack)	1		50923502
26	3PP4044-5008P1	Plate: Guide Rail (N)	1	For ML390 Turbo	51022201
	3PP4044-5155P1	Plate: Guide Rail (W)	1	For ML391 Turbo	51022301
27	3PP4025-2810P2	Cam: Adjust	1		51238601
28	4PP4044-5009P1	Shaft: Carriage (N)	1	For ML390 Turbo	51114201
	4PP4044-5009P2	Shaft: Carriage (W)	1	For ML391 Turbo	51114202
29	3PP4044-5005P1	Plate: FG (L)	1		51022401
30	3PA4044-5050G2	Roller: Pull-up Assy (N)	1	For ML390 Turbo	50411002
	3PA4044-5165G2	Roller: Pull-up Assy (W)		For ML391 Turbo	50411102
31	4PP4044-5116P1	Gear: Idle (LF Motor)(24)	1		51238701
32	4PA4044-5041G2	Frame: Tractor Assy (R)	1		53350302
33	4PA4044-5043G2	Frame: Tractor Assy (L)	1		53350202
34	4PP4025-3335P3	Shaft: Drive	1	For ML390 Turbo	51114403
	4PP4025-3335P4	Shaft: Drive	1	For ML391 Turbo	51114404
35	3PP4044-5046P1	Guide: Tractor Sheet	1	For ML391 Turbo	51022901
36	4PB4044-5095P1	Plate: FG (A)	1		51622701
37	3PP4044-5089P1	Shaft: Change Gear	1		51114301

Copyright 1997, Okidata, Division of OKI America, Inc. All rights reserved. See the OKIDATA Business Partner Exchange (BPX) for any updates to this material. (<http://bpx.okidata.com>)



Service Guide ML390/ML391Turbo

Chapter B Parts Listing

Carriage Option Assembly (Figure 11-4)

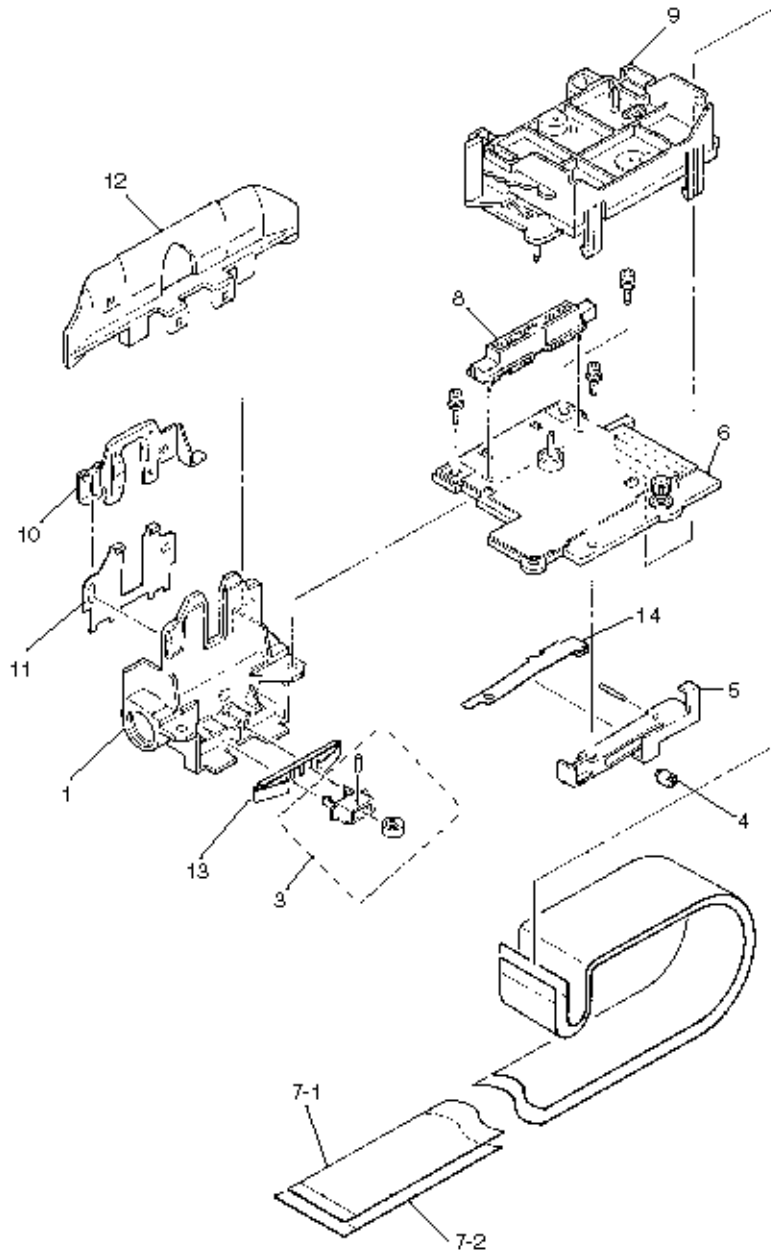

No.	Part No.	Description	Qty	ODA #
1	4PP4044-5061G1	Frame: Carriage	1	53349801
2				

3	4PA4025-3718G1	Assy: Backup Roller/Holder	1		53343201
4	4PP4025-3398P1	Roller: Guide			53341901
5	3PP4044-5065P1	Holder: Guide Roller			53350101
6	4YA4044-5120G1	Motor: Space (Assy) (24)	1		56513701
7	3PP4044-5015P1	Cable: Printhead (24N)	1	For ML390 Turbo	56634001
	3PP4044-5157P1	Cable: Printhead (24W)	1	For ML391 Turbo	56634101
8	3PB4025-1241P1	PC connector (36/40)	1		56719201
9	3PA4044-5070G1	Gear: Case (Assy)	1		51238801
10	3PP4044-5068P1	Clamp: Printhead	1		50709001
11	4PP4044-5067P1	Plate: Printhead	1		51022501
12	3PP4044-5064P1	Protector: Ribbon	1		53077101
13	4PP4025-3397P2	Spring: Backup Roller Holder	1		50925001
14	4PP4044-5066P1	Spring: Guide Roller Holder	1		50931801

Copyright 1997, Okidata, Division of OKI America, Inc. All rights reserved. See the OKIDATA Business Partner Exchange (BPX) for any updates to this material. (<http://bpx.okidata.com>)

Option Spare Parts (Figure 11-5)

Pull-Tractor

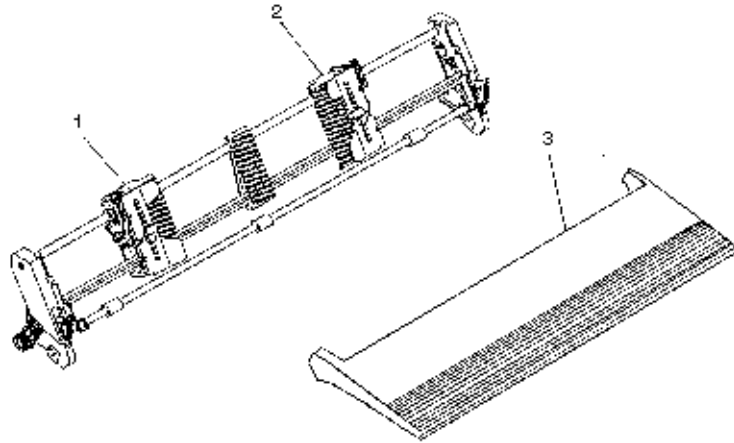

Bottom-Tractor

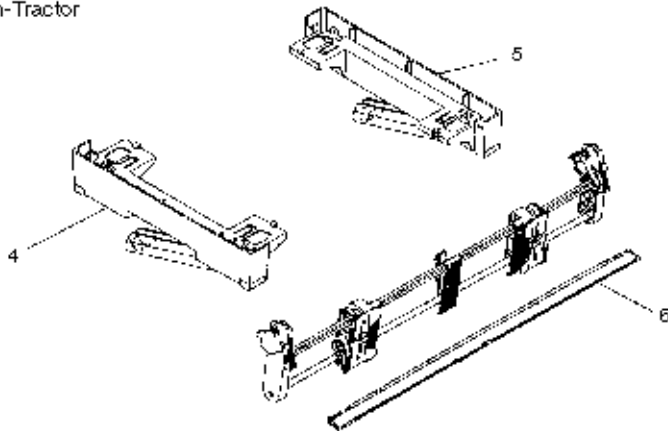

I/F Board

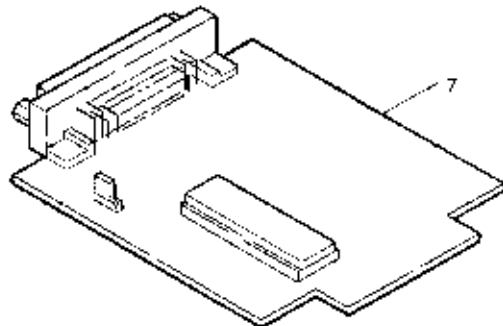

No.	Part No.	Description	Qty	Remarks	ODA#
-----	----------	-------------	-----	---------	------

1	4PA4025-3608 G1	Tractor: Pull & Bottom (Assy) (L)	1		50098001
2	4PA4025-3603 G1	Tractor: Pull & Bottom (Assy) (R)	1		50097901
3	2PP4128-1239 G1	Cover: Tractor Assy (N)	1	For ML390 Turbo	53077201
	2PP4128-1243 G1	Cover: Tractor Assy (W)	1	For ML391 Turbo	53077301
4	1PA4128-1277 G1	Stand: Bottom Push (L)	1		51902301
5	1PA4128-1277 G2	Stand: Bottom Push (R)	1		51902302
6	4PP4094-7385 G1	Knife: Paper (N)	1	For ML390 Turbo	50098701
	4PP4094-7386 G1	Knife: Paper (W)	1	For ML391 Turbo	50098801
7	4YA4021-1050 G1	PCB: LXHI (RS232 I/F)	1		55038901

Copyright 1997, Okidata, Division of OKI America, Inc. All rights reserved. See the OKIDATA Business Partner Exchange (BPX) for any updates to this material. (<http://bpx.okidata.com>)



Service Guide ML390/ML391 Turbo

Chapter C RS-232C Serial Interface Board

APPENDIX C: RS-232C SERIAL INTERFACE BOARD

C1. General

This section describes the operation of the RS-232C Serial Interface board installed in the Printer as an option using a start-stop synchronization and serial communications circuit. This serial interface board is capable of transmitting and receiving simultaneously at speeds up to 19,200 bits per second. Two protocols are available: printer Ready/Busy and X-ON/X-OFF modes.

Copyright 1997, Okidata, Division of OKI America, Inc. All rights reserved. See the OKIDATA Business Partner Exchange (BPX) for any updates to this material. (<http://bpx.okidata.com>)



C2. Operation Description

C2.1 Element Description

(1) 80C51 with MASK ROM

An eight-bit microprocessor controller that controls the following:

- (a.) Serial interface protocol and data transfer through a serial port.
- (b.) Message buffer.
- (c.) Transmission of parallel data to the printer.
- (d.) Serial interface control program

(2) SN75189

An RS-232C standard line receiver

(3) SN75188

An RS-232C standard line driver.

(4) HM6264

An 8192-byte static RAM used as a message buffer.

C2.2 Circuit Description

A block diagram is shown in Figure C-2-1.

Block Diagram (Figure C-2-1)

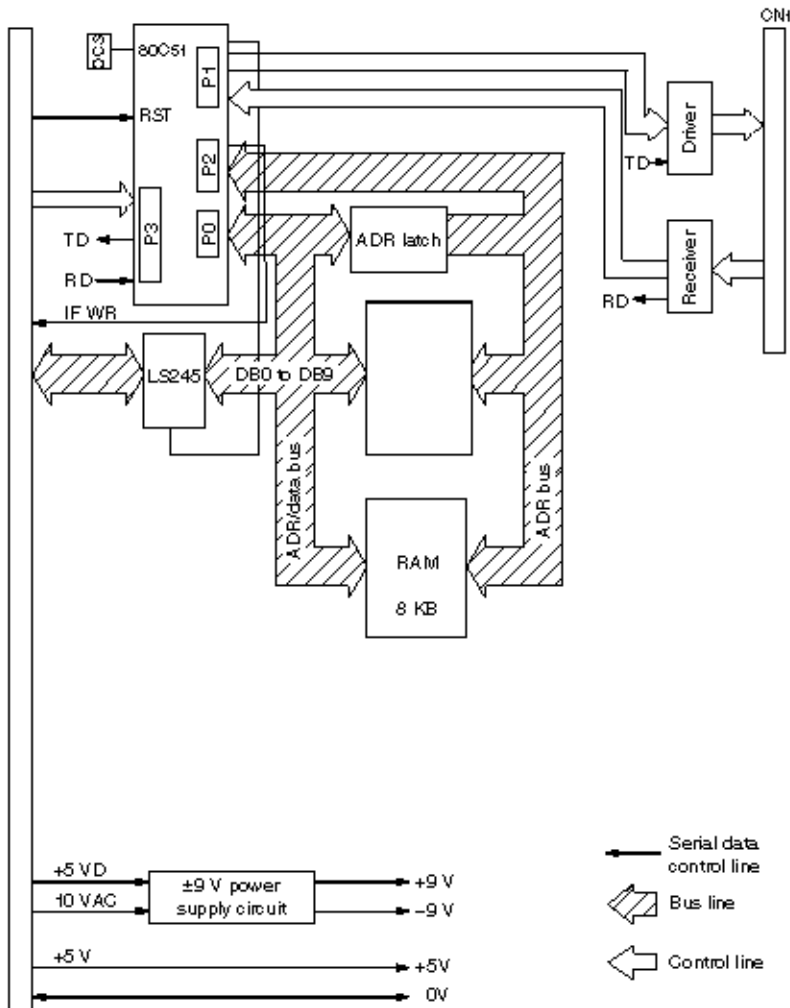

Copyright 1997, Okidata, Division of OKI America, Inc. All rights reserved. See the OKIDATA Business Partner Exchange (BPX) for any updates to this material. (<http://bpx.okidata.com>)



Service Guide ML390/ML391Turbo

Chapter C RS-232C Serial Interface Board

C2.2.01 Operation at Power On

After power is turned on, an RST OUT signal is sent from the printer control board to reset the printer. When the reset is canceled, the 80C51 CPU performs initialization. Initialization consists of setting the 80C51 timer, and setting the serial mode.

Copyright 1997, Okidata, Division of OKI America, Inc. All rights reserved. See the OKIDATA Business Partner Exchange (BPX) for any updates to this material. (<http://bpx.okidata.com>)



Service Guide ML390/ML391Turbo

Chapter C RS-232C Serial Interface Board

C2.2.02 RS-232C Interface

The DTR, SSD, TD and RTS signals output by the 80C51 are converted to RS-232C signals by line driver SN75188 (Q1) and sent to the interface.

In addition, signals DSR, CTS, CD, and RD on the RS232C interface are converted to TTL level by line receiver SN75189 (Q2) and input to the 80C51.

Copyright 1997, Okidata, Division of OKI America, Inc. All rights reserved. See the OKIDATA Business Partner Exchange (BPX) for any updates to this material. (<http://bpx.okidata.com>)

C2.3 Communication Procedure Flowchart

C2.3.01 Mode A (Figure C-2-2)

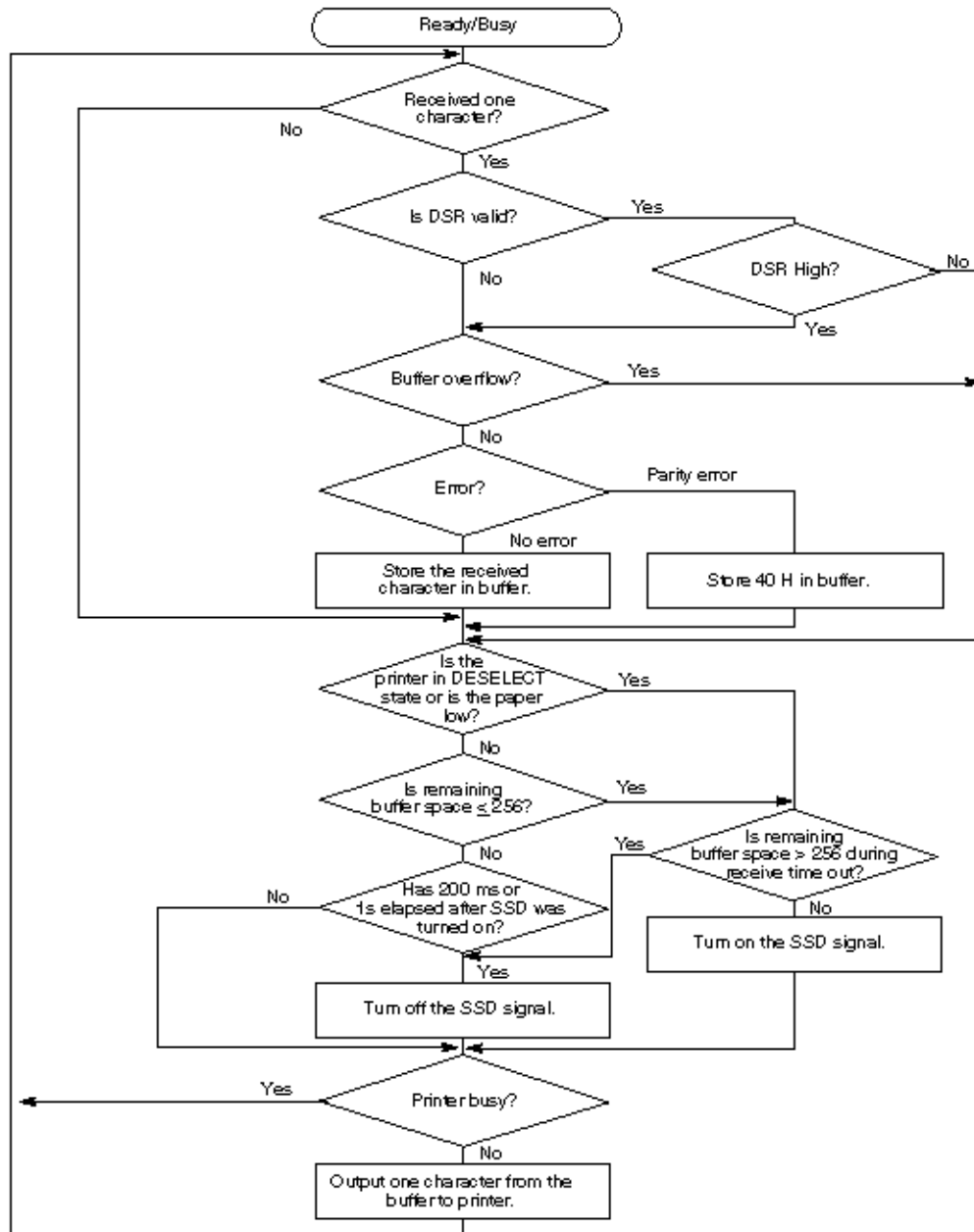

Copyright 1997, Okidata, Division of OKI America, Inc. All rights reserved. See the OKIDATA Business Partner Exchange (BPX) for any updates to this material. (<http://bpx.okidata.com>)



Service Guide ML390/ML391 Turbo
Chapter C RS-232C Serial Interface Board

C2.3.02 Mode B (Figure C-2-3)

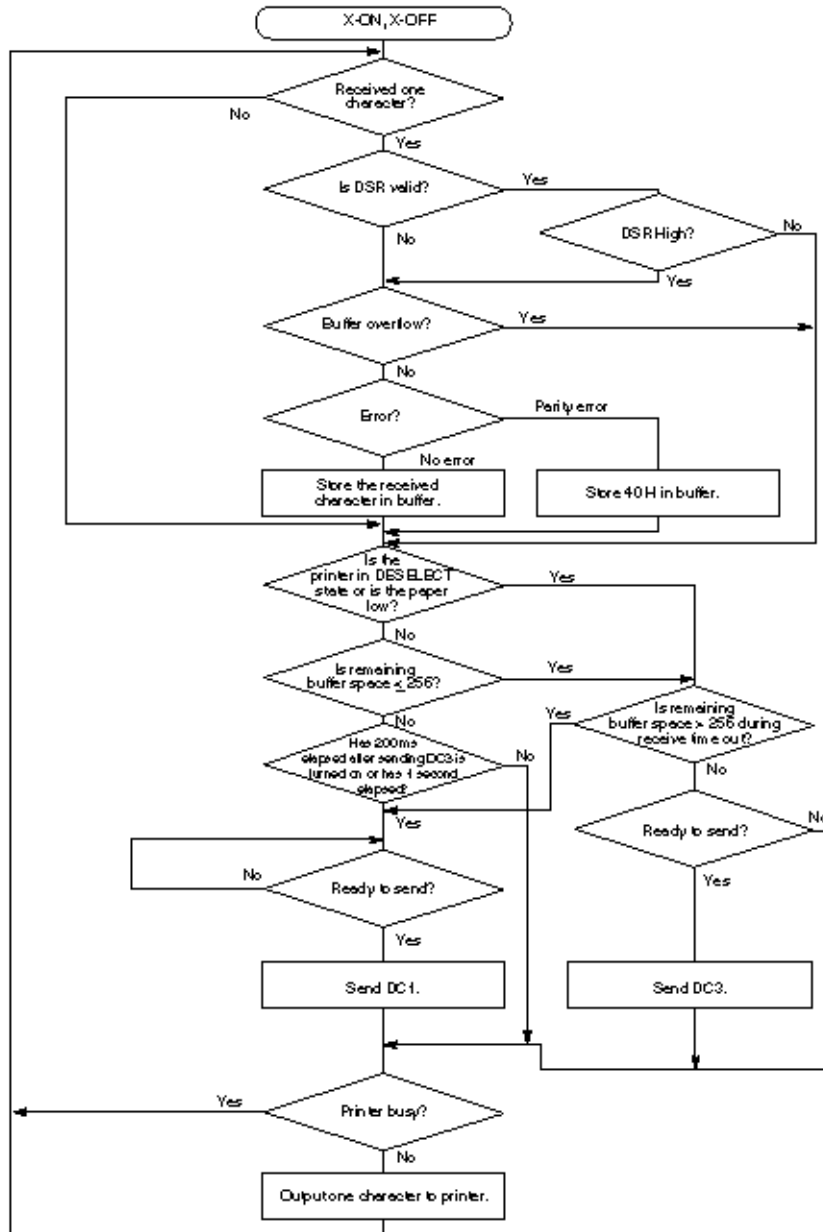

C3. Troubleshooting Flowcharts

C3.1 Before Repairing a Fault

Before servicing the printer, ask the customer in what situation the trouble occurred and record the response.

Before starting troubleshooting, operate the printer in the same situation as that at the time of trouble occurrence to see if the same trouble occurs again. If not, perform the printers self test and thoroughly test the printers functionality. If the trouble is reproducible proceed to the trouble-shooting section.

C3.2 Troubleshooting

(1) Data is not received

(2) Data does not print or data is missing when printed

1 Data is not received

(A protocol is set to READY/BUSY state, and BUSY LINE is in SSD + state.)

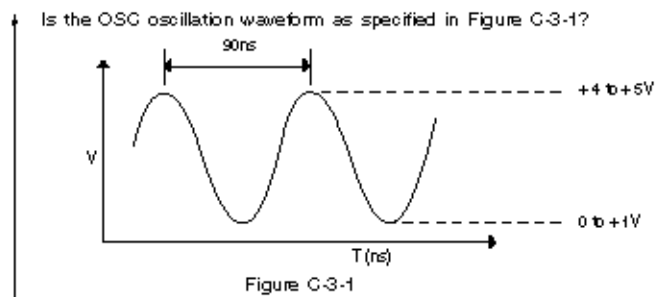

◆ No Replace the OSC.

▼ Yes Is a RST signal in Q3 is as specified in Figure C-3-2?

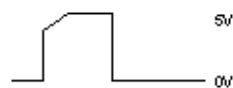

▼ No Check the RST circuit on the SRXC board.



(A)

Yes Are ALE, PSEN, RD, WR, signals as specified in Figure C-3-3?

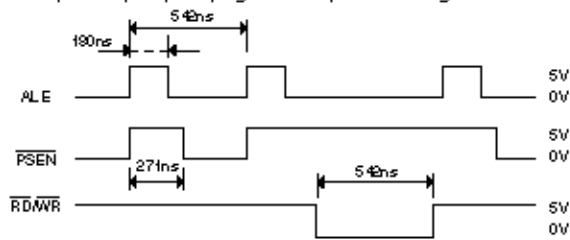

Figure C-3-3

• No Replace the Q3.

Yes Are (T1) SELECT and (INT0) BUSY signals low level?

• No Check Q11 on the SKRA board.

Yes Are +9V and -9V input to Q1?

• No Replace defective component in +9/-9 volt control circuit.

Yes Is pin 1 SSD signal of Q3 High level?

• No Replace the Q3.

Yes Is pin 11 SSD of Q1 low level?

• No Replace the Q1 or the CN1?

Yes Is the RxD of Q3 as specified in Figure C-3-4?

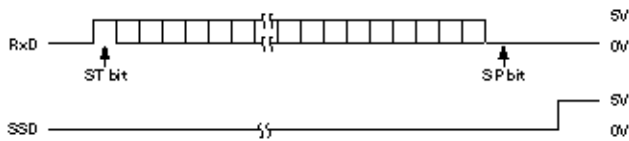

Figure C-3-4

• No Replace the Q2.

Yes Replace the Q3.

2 Data does not print or data is missing when printed

Are RxD and SSD of Q3 as specified in Figure C-3-4?

- No Replace the Q2.

Yes Are WR, and BUS signals of Q3 pin 3 as specified in Figure C-3-5?

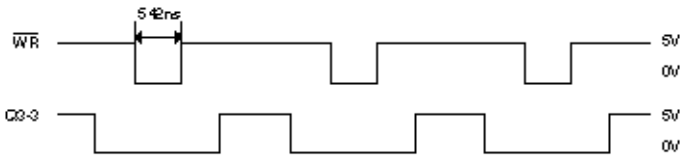

Figure C-3-5

- No Replace the Q3.
- Yes Is the level of a BUS signals at Q7 pins 2-9 the same as that of DB0-7 when WR signal is started?

- No Replace the Q7.
- Yes Is 4 pin of Q6 identical to WR signal in Figure C-3-5?

- No Replace the Q6.
- Yes Check Q7 (LSI: 10S021042) in the SRXD control PCB.



Service Guide ML390/ML391 Turbo

Chapter C RS-232C Serial Interface Board

C3.3 Local Test

C3.3.1 Circuit Test Mode

C3.3.1.1 Setting

(1) Diagnostic test (set by menu)

(2) Test connector

Connect the test connector shown in Figure C-3-6 to the interface connector

Test Connector Connection Diagram (Figure C-3-6)

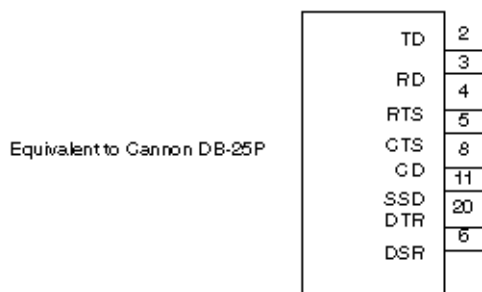

Setup Test

Hold SHIFT and SEL switches to enter Menu Mode.

Move to the Serial I/F Options and continue on the Diagnostic Test option.

Change this option to Yes.

This will setup the Diagnostic Test Program.



Service Guide ML390/ML391 Turbo

Chapter C RS-232C Serial Interface Board

C3.3.1.2 Function

After the settings outlined in Section 3.3.1.1 are completed and power is turned on, the serial interface checks the message buffer memory and interface driver/receiver circuit. It then prints characters.

To start and stop this test, push the SEL switch on the front of the printer.

To cancel the test, hold the SEL and SHIFT switches and turn the printer on.

Move to the menu option for the test and change Diagnostic Test to No.

Here is an explanation of the details of this test .

- (1) The program revision using two numerical characters is printed.
 - (2) "LOOP TEST" is printed.
 - (3) Memory is checked for the message buffer.
 - (4) Prints "OK" is printed if the memory check is OK and "BAD" is printed if the memory check fails.
 - (5) Output level to DTR, RTS, and SSD signals is dropped low. If DSR, CTS, or CD signals is High, "IF BAD" is printed. If DSR, CTS, and CD signals are all Low, "IF OK" is printed.
 - (6) Output level to DTR, RTS, and SSD signals is raised high. If DSR, CTS, or CD signals is Low, "IF BAD" is printed. If DSR, CTS, and CD signals are all High, "IF OK" is printed.
 - (7) Transmits characters codes from 20H to 7FH is transmitted by SD signal. At the same time, characters are received by the RD signal and stored in the message buffer.
 - (8) The characters that were stored in the message buffer as indicated in (7) are printed.
 - (9) Steps (1) through (8) are repeated until test is interrupted.
-